

# Operation panel

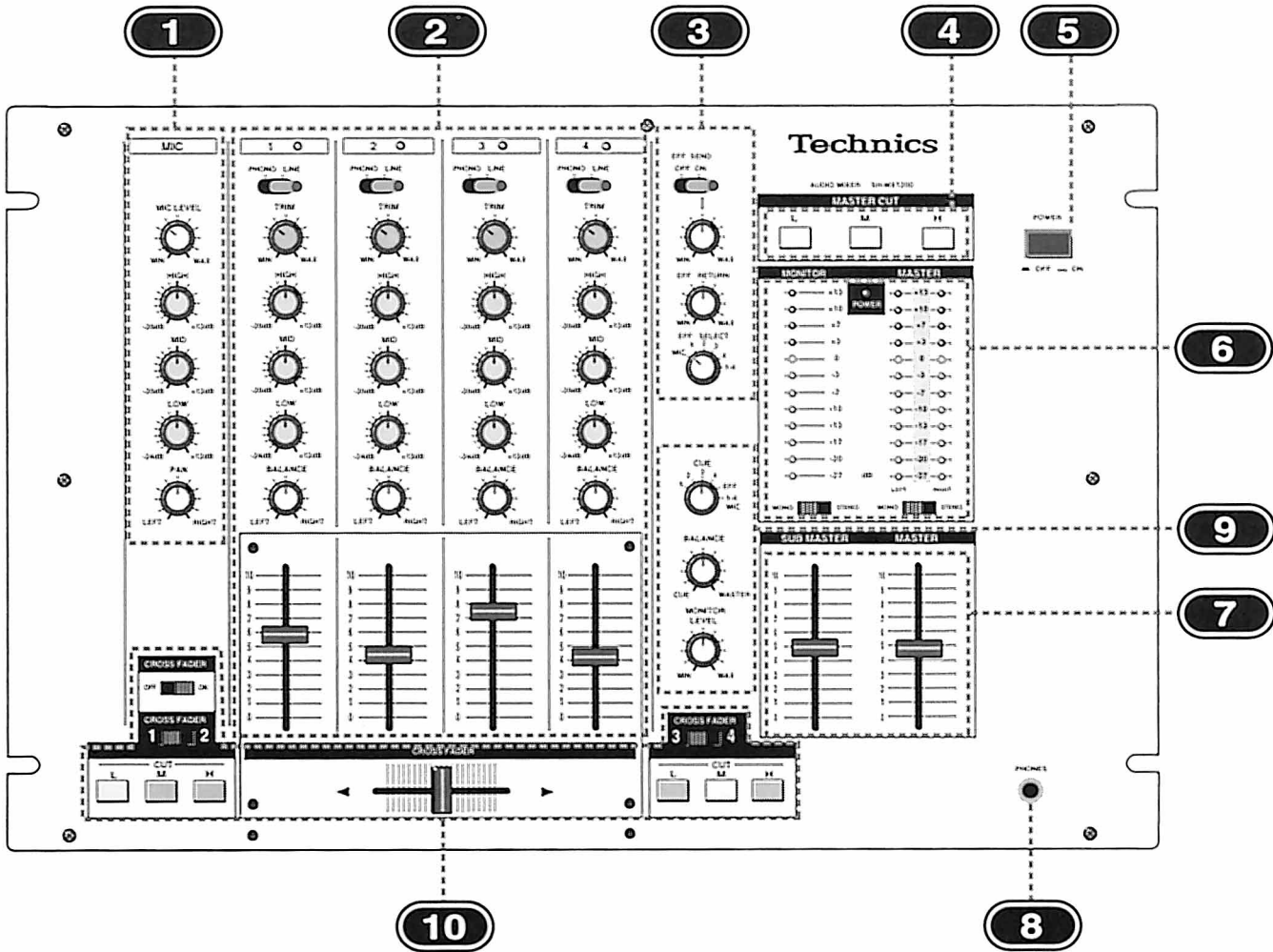

## 1 MIC section

Adjust the sound of a microphone connected to the MIC terminal.

- |                     |                   |
|---------------------|-------------------|
| ■ MIC LEVEL control | Microphone volume |
| ■ HIGH control      | High-range sound  |
| ■ MID control       | Mid-range sound   |
| ■ LOW control       | Low-range sound   |
| ■ PAN control       | Stereo balance    |

## 2 Input signal regulating section

Regulate the signal input from 1IN, 2IN, 3IN and 4IN terminals.

- |                     |                     |
|---------------------|---------------------|
| ■ PHONO/LINE switch | Select input source |
| ■ TRIM control      | Input level         |
| ■ HIGH control      | High-range sound    |
| ■ MID control       | Mid-range sound     |
| ■ LOW control       | Low-range sound     |
| ■ BALANCE control   | Left-right balance  |
| ■ Fader             | Volume              |

**3****External effector section**

Adjust the input/output to an external effector.

■ EFF SEND	Effector output on/off switch and output level control
■ EFF RETURN	Effector input level control
■ EFF SELECT	Effect source selector

**4****MASTER CUT button**

While the button is depressed, the specified sound range of the master output is cut.

■ H (high)	High-range cut
■ M (mid)	Mid-range cut
■ L (low)	Low-range cut

- The sub-master output is also cut.

**5****POWER button**

Turns the audio mixer on and off.

- The POWER indicator lights when the audio mixer is on.

**6****MONITOR/MASTER output level meter**

Display of each output level

- With the MONO/STEREO switch, the output mode of each can be selected.

**7****MASTER/SUB MASTER volume fader**

Adjustment of each output level

**8****PHONES jack**

Connection jack for monitoring headphones

**9****Monitor section**

For monitoring adjustments

■ CUE	Monitor source selector
• When 1, 2, 3 or 4 is selected, the corresponding indicator in the input signal adjustment section lights.	
■ BALANCE control	Adjustment of the volume balance between the MASTER source and the source selected by CUE
■ MONITOR LEVEL control	Headphones volume

**10****CROSS FADER section**

Used to adjust the level balance of the 2 input signals for the FADER.

The level balance between input signal 1 or 2 and input signal 3 or 4 can be adjusted with the sliding fader control.

■ OFF/ON switch	Fader on/off
■ 1/2 and 3/4 switches	Source selection
■ CUT button	The specified sound range is cut with the respective CUT buttons beneath the 1/2 and 3/4 switches.

- Specify H to cut the high range, M for the middle range, and L for the low range. Once a button is pressed (the button lights), the sound is cut until the same button is pressed again (the button goes out).

## Rear panel terminals

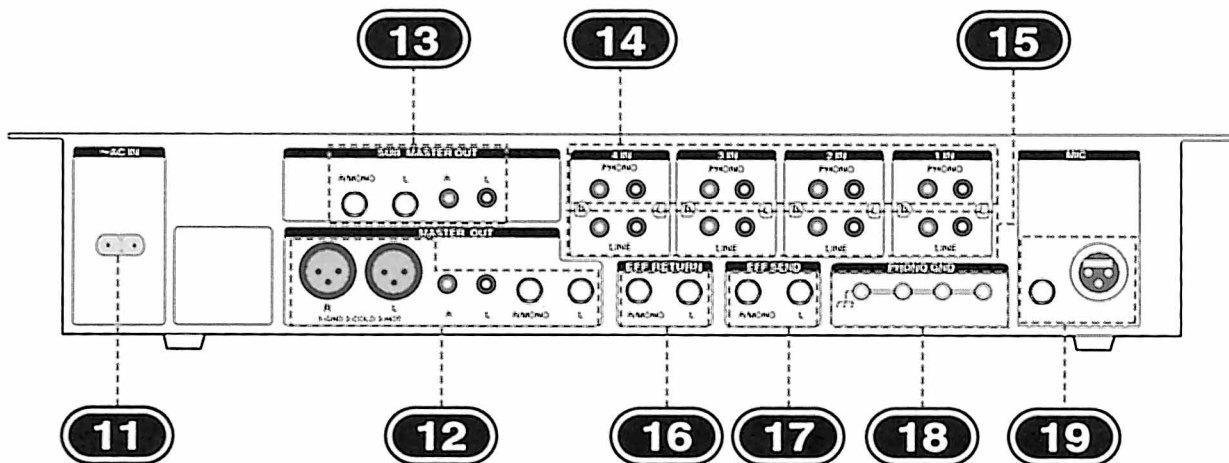

### **11** AC IN (power input)

Connect to the AC power cord (included).

### **12** MASTER OUT terminals

Master output terminals. Balance output, pin and 6.3 mm (1/4") terminals are available.

### **13** SUB MASTER OUT terminals

Sub-master output terminals for a monitor booth. 6.3 mm (1/4") and pin terminals are available.

### **14** PHONO terminals

Input terminals for PHONO

### **15** LINE terminals

LINE input terminals

### **16** EFF RETURN terminals

Terminals to return the external effector signal

### **17** EFF SEND terminals

Terminals to send the signal to an external effector

### **18** PHONO GND terminal

To prevent hum and other interference. Affix the record player ground wire to this terminal.

### **19** MIC (microphone input) terminals

Microphone connection terminals. Large-type and balance input terminals are available.

- If you connect a monaural cord to the 6.3 mm (1/4") plug terminals, connect to R/MONO and do not connect anything to L.

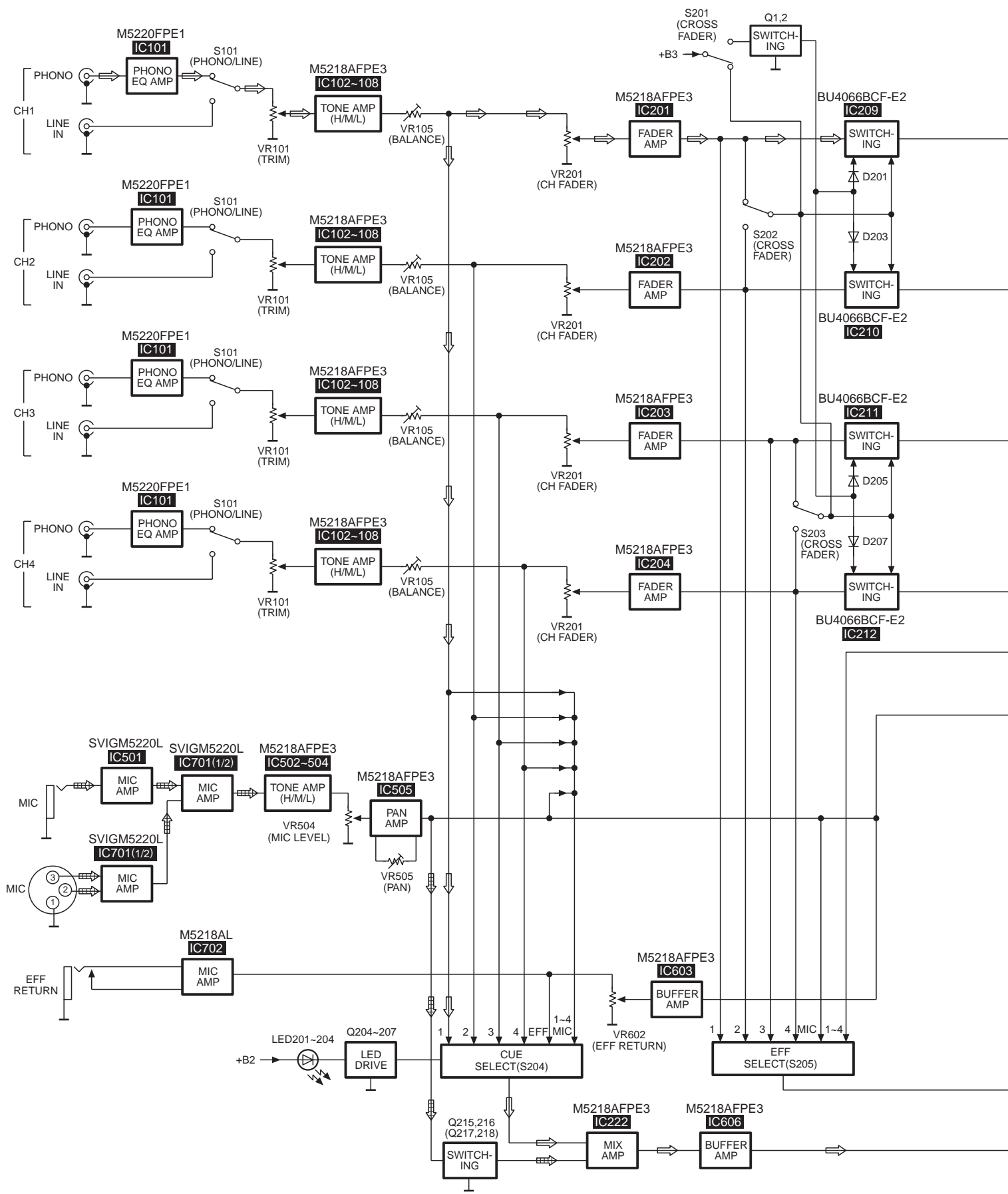

NOTES

- ⇨ : PHONO(1) SIGNAL LINE
- ⇨ : MIC SIGNAL LINE
- ( ) indicates pin No. Right channel.

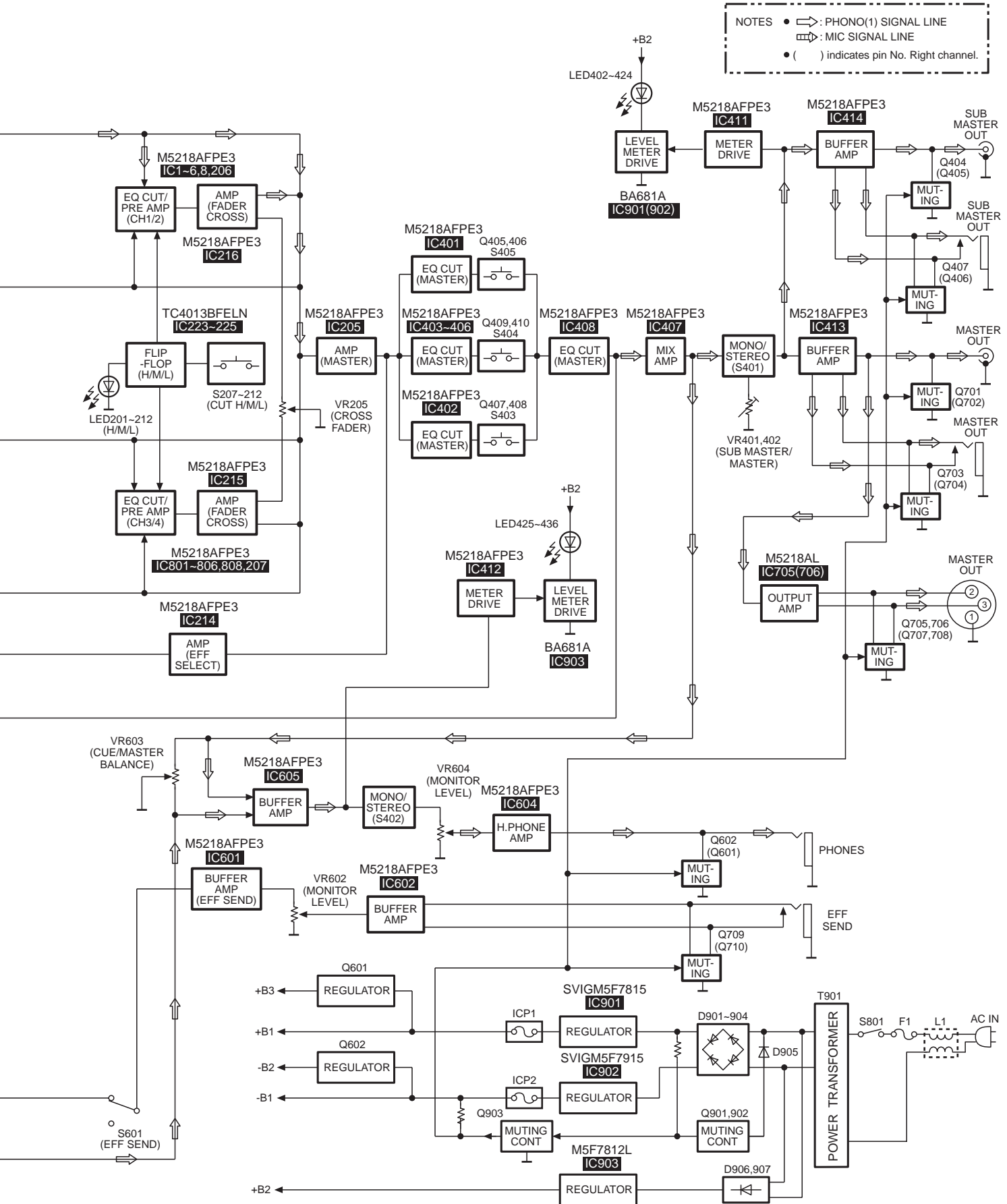

Note: This printed circuit board diagram may be modified at any time with the development of new technology.

※ Tilt the parts in the direction of arrows as follows:  
Q7, C25, C26, C33, C34 and C816



# K MAIN P.C.B. (SIDE : A)

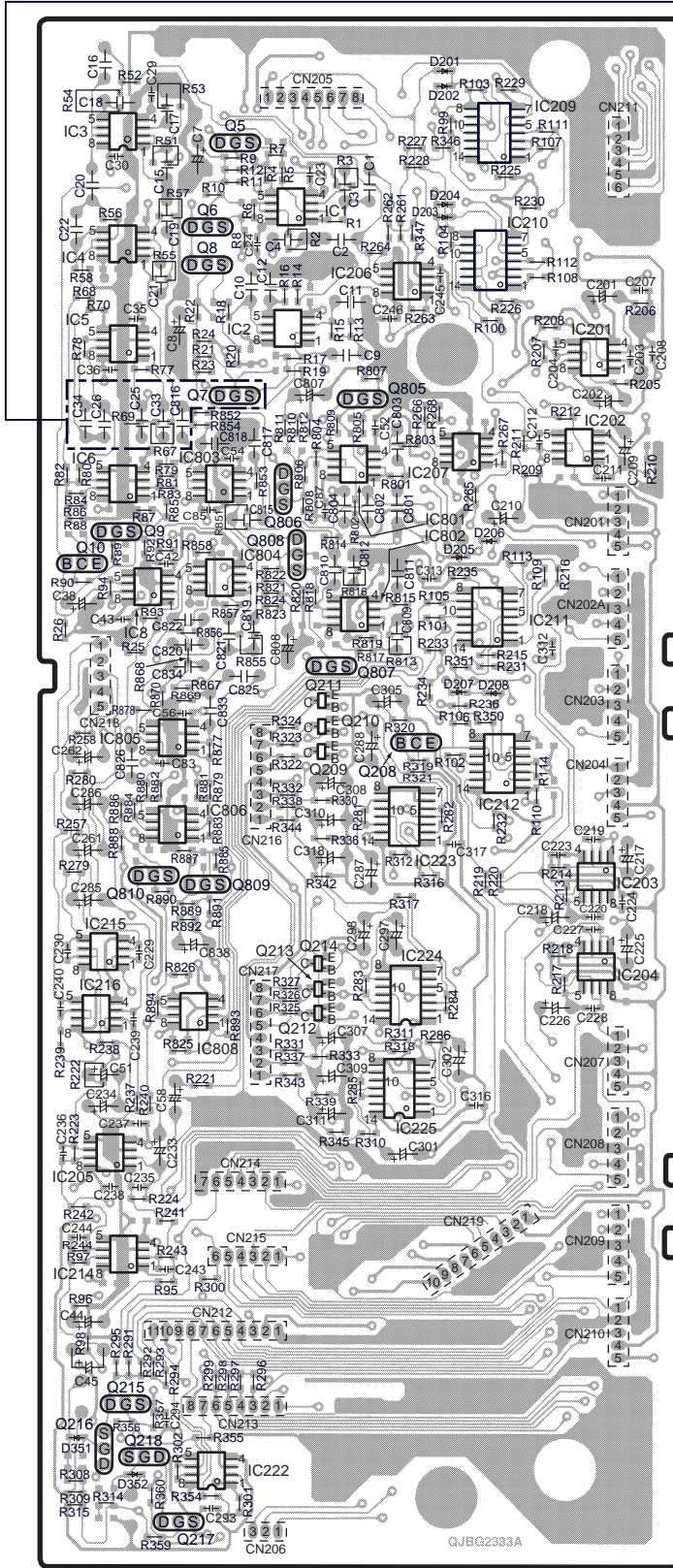

## ELECTRICAL PARTS LOCATION

Ref. No.	Lo. No.	Ref. No.	Lo. No.	Ref. No.	Lo. No.	Ref. No.	Lo. No.	Ref. No.	Lo. No.
<b>K MAIN P.C.B. (SIDE : A)</b>									
IC1	2B	R7	2B	R225	2C	R360	8A	C51	6A
IC2	3B	R8	2B	R226	3C	R801	3C	C52	3C
IC3	2A	R9	2B	R227	2C	R802	4B	C54	3B
IC4	2A	R10	2B	R228	2C	R803	3C	C56	4B
IC5	3A	R11	2B	R229	2C	R804	3B	C58	6B
IC6	3A	R12	2B	R230	2C	R805	3B	C83	5B
IC8	4A	R13	3B	R231	4C	R806	3B	C85	4B
IC201	3D	R14	3B	R232	5C	R807	3B	C87	4B
IC202	3C	R15	3B	R233	4C	R808	4B	C201	3D
IC203	5D	R16	3B	R234	4C	R809	3B	C202	3D
IC204	6D	R17	3B	R235	4C	R810	3B	C203	3D
IC205	7A	R18	3B	R236	4C	R811	3B	C204	3C
IC206	2C	R19	3B	R237	6A	R812	3B	C207	3D
IC207	3C	R20	3B	R238	6A	R813	4C	C208	3D
IC209	2C	R21	3B	R239	6A	R814	4B	C209	3D
IC210	2C	R22	3B	R240	6A	R815	4C	C210	4C
IC211	4C	R23	3B	R241	7B	R816	4B	C211	3D
IC212	5C	R24	3B	R242	7A	R817	4B	C212	3C
IC214	7A	R25	4A	R243	7B	R818	4B	C217	5D
IC215	6A	R26	4A	R244	7A	R819	4B	C218	5C
IC216	6A	R51	2B	R257	5A	R820	4B	C219	5D
IC222	8B	R52	2A	R258	5A	R821	4B	C220	5D
IC223	5C	R53	2B	R261	2C	R822	4B	C223	5C
IC224	6C	R54	2A	R262	2C	R823	4B	C224	5D
IC225	6C	R55	2B	R263	3C	R824	4B	C225	6D
IC801	3B	R56	2A	R264	2C	R825	6B	C226	6C
IC802	4B	R57	2B	R265	3C	R826	6B	C227	5C
IC803	3B	R58	2A	R266	3C	R851	4B	C228	6C
IC804	4B	R67	3B	R267	3C	R852	3B	C229	6A
IC805	5B	R68	3A	R268	3C	R853	3B	C230	6A
IC806	5B	R69	3A	R279	5A	R854	3B	C233	7B
IC808	6B	R70	3A	R280	5A	R855	4B	C234	6A
Q5	2B	R77	3B	R281	5B	R856	4B	C235	7A
Q6	2B	R78	3A	R282	5C	R857	4B	C236	7A
Q7	3B	R79	3B	R283	6B	R858	4B	C237	6A
Q8	2B	R80	3A	R284	6C	R867	4B	C238	7A
Q9	4A	R81	3B	R285	6B	R868	4B	C239	6A
Q10	4A	R82	3A	R286	6C	R869	4B	C240	6A
Q208	5C	R83	3B	R291	8A	R870	4B	C243	7B
Q209	5B	R84	3A	R292	8A	R877	5B	C244	7A
Q210	5B	R85	4B	R293	8A	R878	4A	C245	2C
Q211	4B	R86	4A	R294	8B	R879	5B	C246	3C
Q212	6B	R87	4A	R295	8A	R880	5A	C261	5A
Q213	6B	R88	4A	R296	8B	R881	5B	C262	5A
Q214	6B	R89	4A	R297	8B	R882	5B	C285	5A
Q215	8A	R90	4A	R298	8B	R883	5B	C286	5A
Q216	8A	R91	4B	R299	8B	R884	5A	C287	5C
Q217	8B	R92	4A	R300	7B	R885	5B	C288	5C
Q218	8A	R93	4A	R301	8B	R886	5A	C293	8B
Q805	3B	R94	4A	R302	8B	R887	5B	C294	8B
Q806	3B	R95	7B	R308	8A	R888	5A	C297	6C
Q807	4B	R96	7A	R309	8A	R889	5B	C298	6B
Q808	4B	R97	7A	R310	6B	R890	5B	C301	7C
Q809	5B	R98	7A	R311	6C	R891	5B	C302	6C
Q810	5A	R99	2C	R312	5C	R892	5B	C305	4C
D201	1C	R100	3C	R314	8A	R893	6B	C307	6B
D202	2C	R101	4C	R315	8A	R894	6B	C308	5B
D203	2C	R102	5C	R316	5C	C1	2B	C309	6B
D204	2C	R103	2C	R317	5C	C2	2B	C310	5B
D205	4C	R104	2C	R318	6C	C3	2B	C311	6B
D206	4C	R105	4C	R319	5C	C4	2B	C312	4C
D207	4C	R106	5C	R320	5C	C7	2B	C313	4C
D208	4C	R107	2C	R321	5C	C8	3B	C316	6C
D351	8A	R108	2C	R322	5B	C9	3B	C317	5C
D352	8A	R109	4C	R323	5B	C10	2B	C318	5B
CN201	4D	R110	5C	R324	5B	C11	3B	C801	4C
CN202A	4D	R111	2C	R325	6B	C12	2B	C802	4B
CN203	4D	R112	2C	R326	6B	C15	2B	C803	3C
CN204	5D	R113	4C	R327	6B	C16	1A	C804	4B
CN205	2B	R114	5C	R330	5B	C17	2B	C805	3B
CN206	8B	R205	3D	R331	6B	C18	2A	C807	3B
CN207	6D	R206	3D	R332	5B	C19	2B	C808	4B
CN208	6D	R207	3C	R333	6B	C20	2A	C809	4C
CN209	7D	R208	3C	R336	5B	C21	2B	C810	4B
CN210	7D	R209	3C	R337	6B	C22	2A	C811	4C
CN211	2D	R210	3D	R338	5B	C23	2B	C812	4B
CN212	7B	R211	3C	R339	6B	C24	2B	C815	4B
CN213	8B	R212	3C	R342	5B	C25	3A	C816	3B
CN214	7B	R213	5C	R343	6B	C26	3A	C817	3B
CN215	7B	R214	5C	R344	5B	C29	2A	C818	3B
CN216	5B	R215	4C	R345	6B	C30	2A	C819	4B
CN217	6B	R216	4C	R346	2C	C33	3B	C820	4B
CN218	4A	R217	6C	R347	2C	C34	3A	C821	4B
CN219	7C	R218	6C	R350	5C	C35	3A	C822	4B
R1	2B	R219	5C	R351	4C	C36	3A	C825	4B
R2	2B	R220	5C	R354	8B	C38	4A	C826	5A
R3	2B	R221	6B	R355	8B	C42	4B	C833	4B
R4	2B	R222	6A	R356	8A	C43	4A	C834	4B
R5	2B	R223	7A	R357	8A	C44	7A	C838	6B
R6	2B	R224	7A	R359	8A	C45	7A		

A

B

C

D

E

F

1

**K** MAIN P.C.B. (SIDE : B)

2

3

4

5

6

7

8

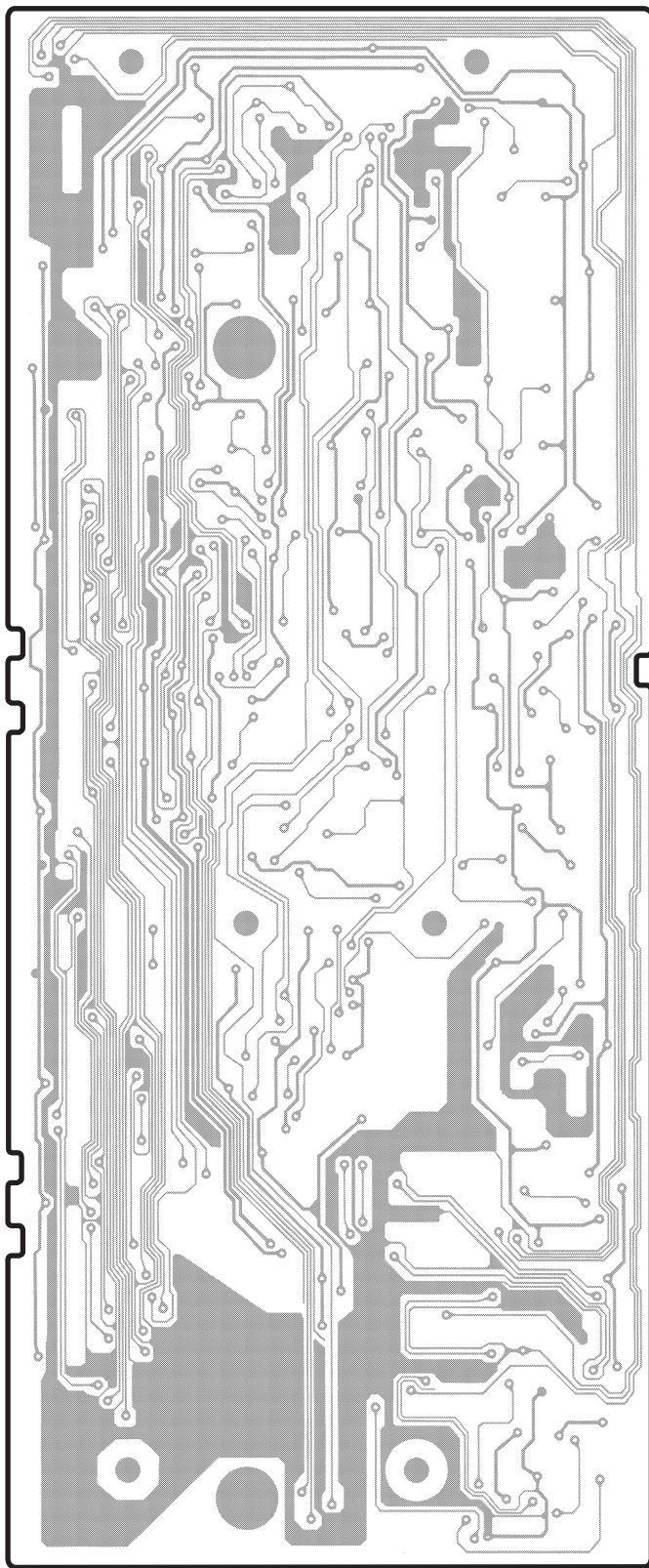

**A** INPUT (1)  
P.C.B.

**C** INPUT (3)  
P.C.B.

**B** INPUT (2)  
P.C.B.

**D** INPUT (4)  
P.C.B.

**W** BALANCE P.C.B.

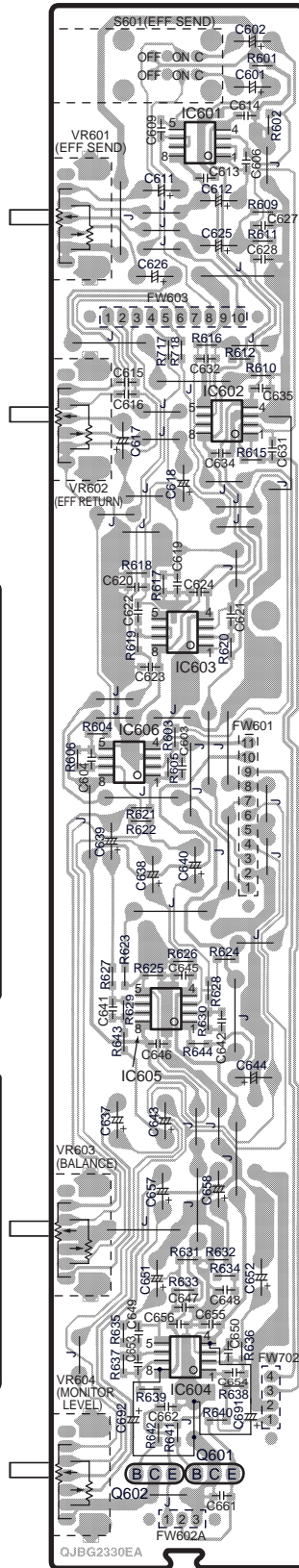
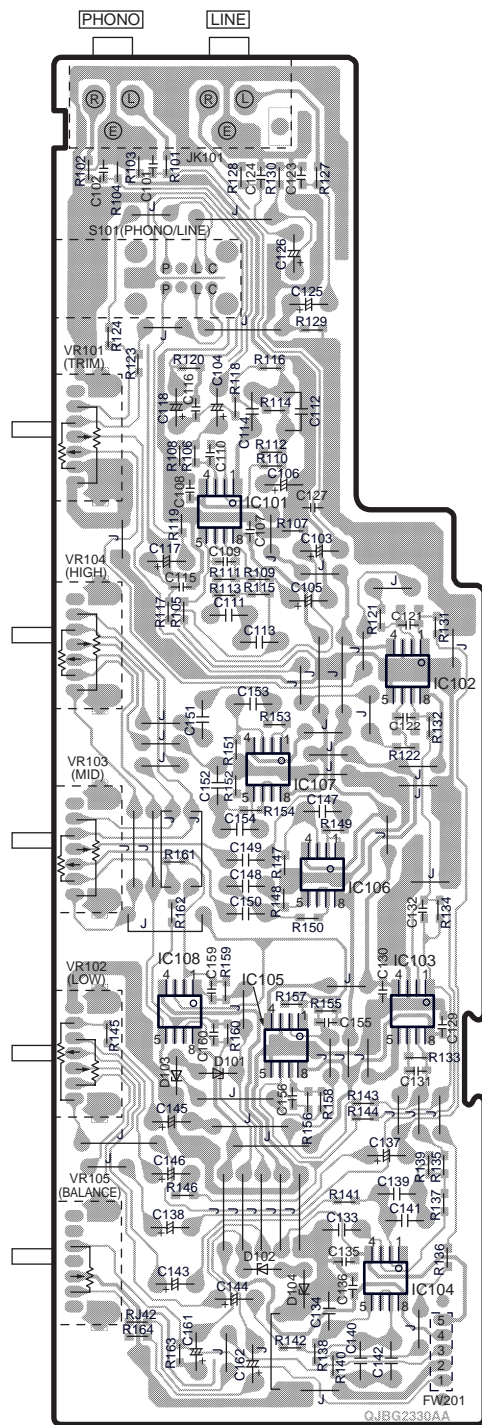

**ELECTRICAL PARTS LOCATION**

Ref. No.	Lo. No.	Ref. No.	Lo. No.	Ref. No.	Lo. No.
<b>A - D INPUT (1)-(4) P.C.B.</b>					
IC101	4B	R130	2B	C112	3B
IC102	4B	R131	4C	C113	4B
IC103	6B	R132	4C	C114	3B
IC104	7B	R133	6C	C115	4A
IC105	6B	R134	5C	C116	3B
IC106	5B	R135	6C	C117	4A
IC107	5B	R136	7C	C118	3A
IC108	6A	R137	7C	C121	4B
D101	6B	R138	7B	C122	4B
D102	7B	R139	6C	C123	2B
D103	6A	R140	7B	C124	2B
D104	7A	R141	7B	C125	3B
VR101	3A	R142	7B	C126	2B
VR102	6A	R143	6B	C127	6C
VR103	5A	R144	6B	C129	6C
VR104	4A	R145	6A	C130	6B
VR105	7A	R146	7A	C131	6C
S101	2A	R147	5B	C132	5C
JK101	2A	R148	5B	C133	7B
FW201	7C	R149	5B	C134	7B
R101	2A	R150	5B	C135	7B
R102	2A	R151	5B	C136	7B
R103	2A	R152	5B	C137	6B
R104	2A	R153	4B	C138	7A
R105	4A	R154	5B	C139	7B
R106	3B	R155	6B	C140	7B
R107	4B	R156	6B	C141	7B
R108	3A	R157	6B	C142	7A
R109	4B	R158	6B	C143	7A
R110	3B	R159	6B	C144	7B
R111	4B	R160	6B	C145	6A
R112	3B	R161	5A	C146	6A
R113	4B	R162	5A	C147	5B
R114	3B	R163	7A	C148	5B
R115	4B	R164	7A	C149	5B
R116	3B	RJ42	7A	C150	5B
R117	4A	C101	2A	C151	4B
R118	3B	C102	2A	C152	5B
R119	4A	C103	4B	C153	4B
R120	3A	C104	3B	C154	5B
R121	4B	C105	4B	C155	6B
R122	5B	C106	3B	C156	6B
R123	3A	C107	4B	C159	6B
R124	3A	C108	3A	C160	6B
R127	2B	C109	4B	C161	7B
R128	2B	C110	3B	C162	7B
R129	3B	C111	4B		

<b>W BALANCE P.C.B.</b>					
IC601	2D	R626	6D	C622	4C
IC602	3D	R627	6C	C623	4D
IC603	4D	R628	6C	C624	4D
IC604	7D	R629	6C	C625	2D
IC605	6D	R630	6D	C626	2D
IC606	5C	R631	7D	C627	2D
Q601	8D	R632	7D	C628	2D
Q602	8D	R633	7D	C631	3D
VR601	2C	R634	7D	C632	3D
VR602	3C	R635	7C	C634	3D
VR603	7C	R636	7D	C635	3D
VR604	8C	R637	7C	C637	6C
S601	1C	R638	8D	C638	5D
FW601	5D	R639	8D	C639	5C
FW602A	8D	R640	8D	C640	5D
FW603	3D	R641	8D	C641	6C
FW702	8D	R642	8C	C642	6D
R601	1D	R643	6C	C643	6D
R602	2D	R644	6D	C644	6D
R603	5D	R717	3D	C645	6D
R604	5C	R718	3D	C646	6D
R605	5D	C601	2D	C647	7D
R606	5C	C602	1D	C648	7C
R609	2D	C603	5D	C649	7C
R610	3D	C604	5C	C650	7D
R611	2D	C605	2D	C651	7D
R612	3D	C606	2D	C652	7C
R615	3D	C611	2D	C653	7C
R616	3D	C612	2D	C654	8D
R617	4D	C613	2D	C655	7D
R618	4C	C614	2D	C656	7D
R619	4C	C615	3C	C657	7D
R620	4D	C616	3C	C658	7D
R621	5C	C617	3C	C661	8D
R622	5C	C618	3D	C662	8D
R623	6C	C619	4D	C691	8D
R624	6D	C620	4C	C692	8C
R625	6D	C621	4D		

1  
2  
3  
4  
5  
6  
7  
8



### E CROSS FADER SW(A) P.C.B.

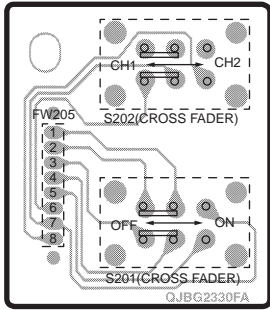

(SXPG233011F)

### M CUT SW(A) P.C.B.

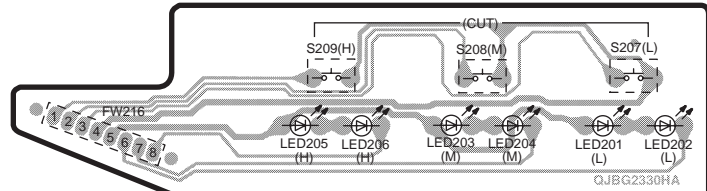

(SXPG233011H)

### F CROSS FADER SW(B) P.C.B.

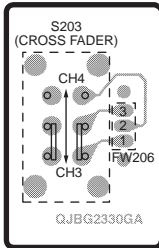

(SXPG233011G)

### L CUT SW(B) P.C.B.

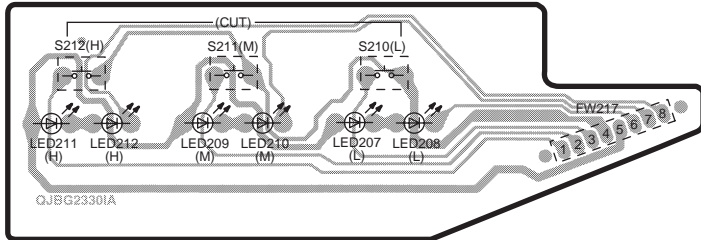

(SXPG233011I)

### X HEADPHONES JACK P.C.B.

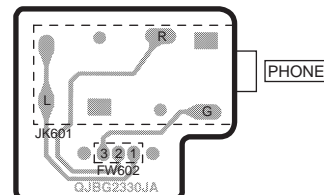

(SXPG233011J)

#### ELECTRICAL PARTS LOCATION

Ref. No.	Lo. No.	Ref. No.	Lo. No.	Ref. No.	Lo. No.
<b>E</b> CROSS FADER SW(A) P.C.B.					
S201	2B	S202	1B	FW205	2A
<b>F</b> CROSS FADER SW(B) P.C.B.					
S203	4A	FW206	4B		
<b>M</b> CUT SW(A) P.C.B.					
LED201	2F	LED205	2D	S209	1D
LED202	2F	LED206	2E	FW216	2C
LED203	2E	S207	1F		
LED204	2E	S208	1E		
<b>L</b> CUT SW(B) P.C.B.					
LED207	4E	LED211	4C	S212	4C
LED208	4E	LED212	4C	FW217	4F
LED209	4D	S210	4E		
LED210	4D	S211	4D		
<b>X</b> HEADPHONES JACK P.C.B.					
JK601	6D	FW602	6D		
<b>N</b> CROSS FADER P.C.B.					
VR205	8E	CN218	8E		

### N CROSS FADER P.C.B.

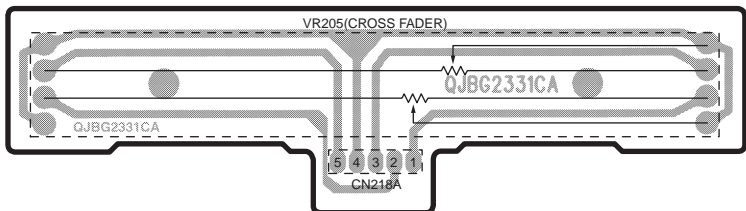

[Keeping to the rule of unit supply, we do not supply single parts.(RFKFHM1200B)]

### U CHANNEL VIEW P.C.B.

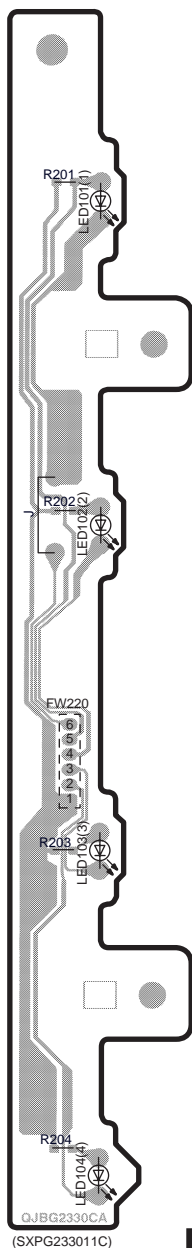

### T MIC P.C.B.

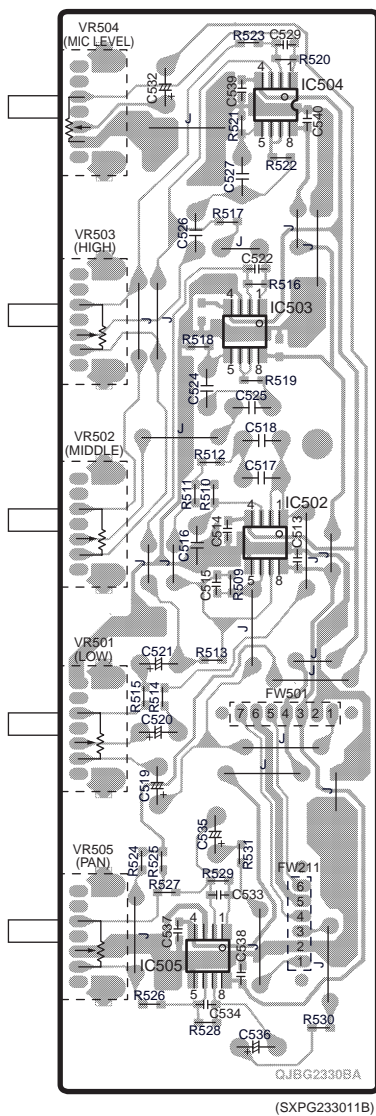

### ELECTRICAL PARTS LOCATION

Ref. No.	Lo. No.	Ref. No.	Lo. No.
<b>U CHANNEL VIEW P.C.B.</b>			
LED101	2A	R201	2A
LED102	4A	R202	4A
LED103	5A	R203	5A
LED104	7A	R204	6A
FW220	5A		

### T MIC P.C.B.

IC502	4C	R527	5C
IC503	3C	R528	6C
IC504	2D	R529	5C
IC505	6C	R530	6D
VR501	5C	R531	5C
VR502	4C	C513	4D
VR503	3C	C514	4C
VR504	2C	C515	4C
VR505	5C	C516	4C
FW211	5D	C517	3C
FW501	4D	C518	3C
R509	4C	C519	5C
R510	3C	C520	5C
R511	3C	C521	4C
R512	3C	C522	2C
R513	4C	C524	3C
R514	4C	C525	3C
R515	4C	C526	2C
R516	3C	C527	2C
R517	2C	C529	1D
R518	3C	C532	2C
R519	3C	C533	5C
R520	2D	C534	6C
R521	2C	C535	5C
R522	2D	C536	6C
R523	1C	C537	5C
R524	5C	C538	6C
R525	5C	C539	2C
R526	6C	C540	2D

### V SIGNAL SELECT P.C.B.

Q204	8D	FW212	8E
Q205	7D	FW213	8E
Q206	8D	FW214	8C
Q207	8D	FW215	8C
D901A	7D	FW603A	8B
D902A	7D	R350	8E
D903A	7D	R351	8E
S204	7E	R352	8E
S205	7C	R353	8E
CN220	8D	C205	8D

### V SIGNAL SELECT P.C.B.

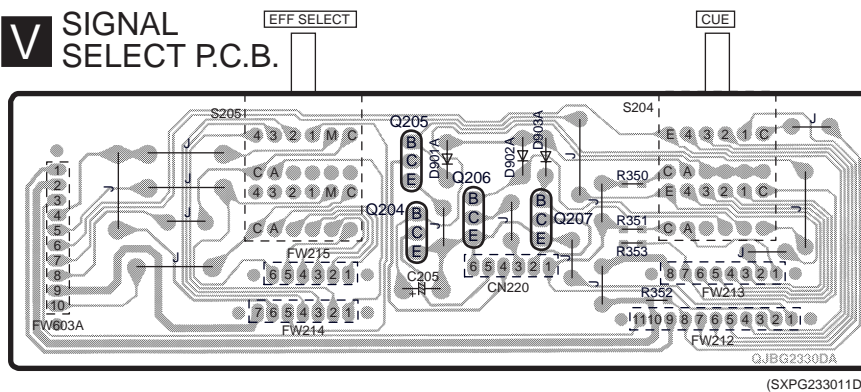

**O** LEVEL INDICATOR P.C.B.

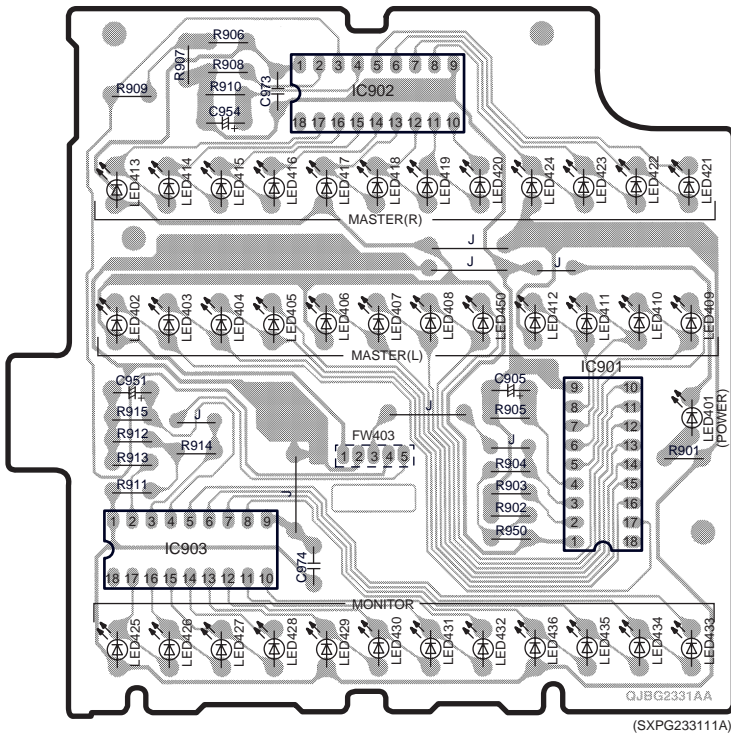

**P** MASTER CUT SW P.C.B.

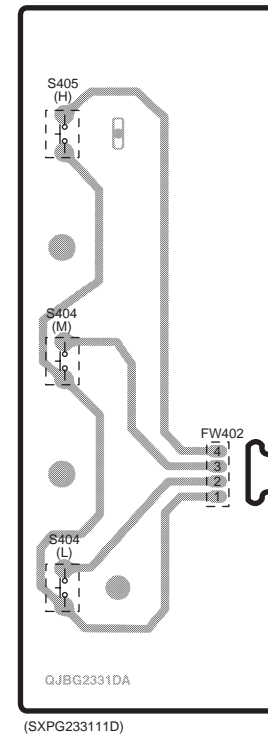

**R** MASTER FADER P.C.B.

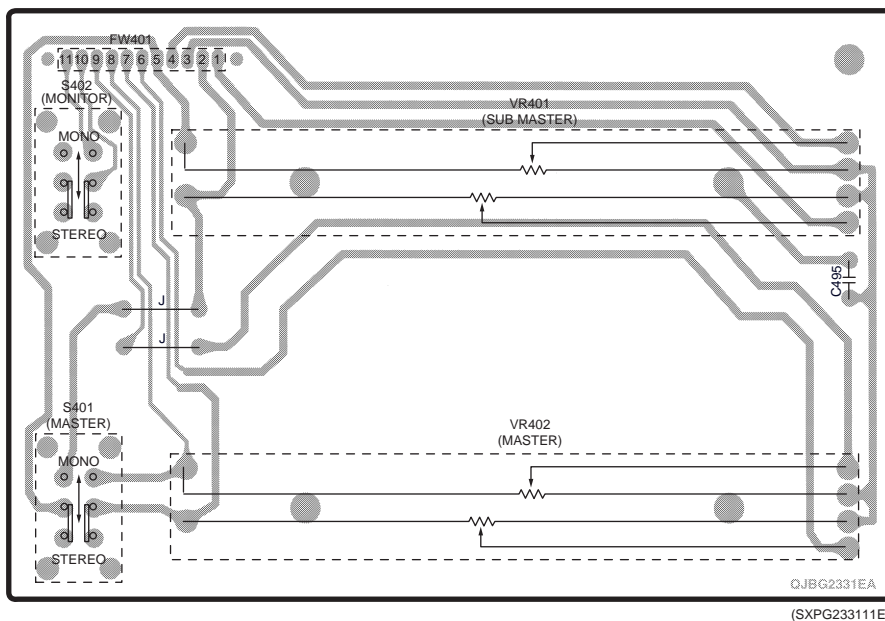

■ ELECTRICAL PARTS LOCATION

Ref. No.	Lo. No.	Ref. No.	Lo. No.
<b>LEVEL INDICATOR P.C.B.</b>			
IC901	3C	LED429	4B
IC902	2B	LED430	4B
IC903	4B	LED431	4C
LED401	3D	LED432	4C
LED402	3A	LED433	4D
LED403	3B	LED434	4D
LED404	3B	LED435	4C
LED405	3B	LED436	4C
LED406	3B	LED450	3C
LED407	3B	FW403	3B
LED408	3C	R901	3D
LED409	3D	R902	3C
LED410	3D	R903	3C
LED411	3C	R904	3C
LED412	3C	R905	3C
LED413	2A	R906	1B
LED414	2B	R907	1B
LED415	2B	R908	1B
LED416	2B	R909	2A
LED417	2B	R910	2B
LED418	2B	R911	3A
LED419	2C	R912	3A
LED420	2C	R913	3A
LED421	2D	R914	3B
LED422	2D	R915	3A
LED423	2C	R950	4C
LED424	2C	C905	3C
LED425	4A	C951	3A
LED426	4B	C954	2B
LED427	4B	C973	2B
LED428	4B	C974	4B
<b>MASTER CUT SW P.C.B.</b>			
S403	4E	S405	2E
S404	3E	FW402	3E
<b>MASTER FADER P.C.B.</b>			
VR401	6C	S402	6A
VR402	8C	FW401	6A
S401	8A	C495	7E



# Z POWER SUPPLY P.C.B.

1  
2  
3  
4  
5  
6  
7  
8

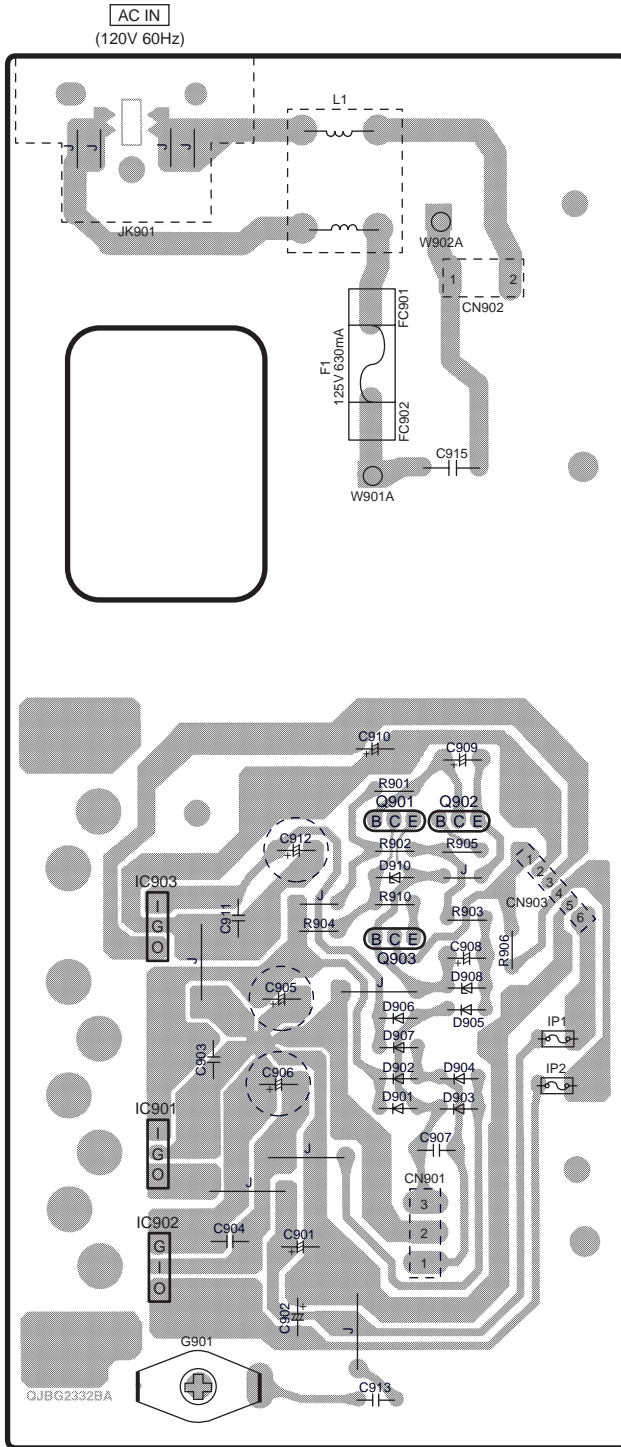

## ELECTRICAL PARTS LOCATION

Ref. No.	Lo. No.	Ref. No.	Lo. No.
<b>Z POWER SUPPLY P.C.B.</b>			
IC901	6A	IP2	6C
IC902	7B	W901A	3C
IC903	5B	W902A	2C
Q901	5C	G901	7B
Q902	5C	R901	5C
Q903	5C	R902	5C
D901	6C	R903	5C
D902	6C	R904	5B
D903	6C	R905	5C
D904	6C	R906	5C
D905	6C	R910	5C
D906	6C	C901	7B
D907	6C	C902	7B
D908	5C	C903	6B
D910	5C	C904	7B
L1	2B	C905	6B
F1	3C	C906	6B
CN901	7C	C907	6C
CN902	2C	C908	5C
CN903	5C	C909	4C
JK901	2B	C910	4C
FC901	2C	C911	5B
FC902	3C	C912	5B
E901	7B	C913	7C
IP1	6C	C915	3C

**S** IN/OUT TERMINAL P.C.B.

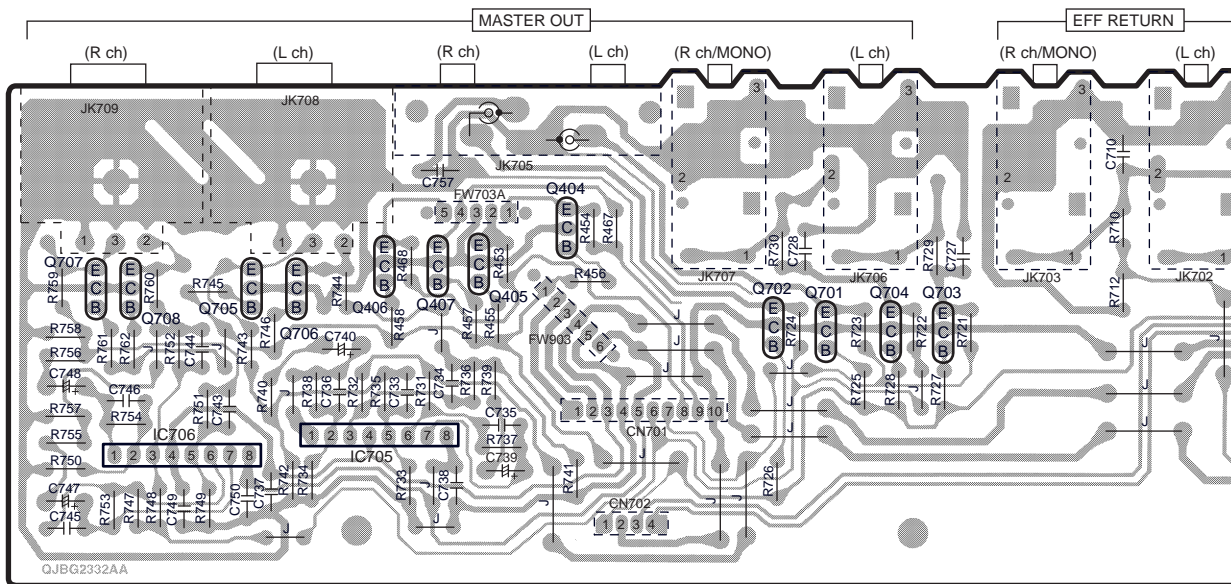

[Keeping to the rule of unit supply, we do not supply single parts.(RFKFHMX1200A)]

- G** FADER (1) P.C.B.
- H** FADER (2) P.C.B.
- I** FADER (3) P.C.B.
- J** FADER (4) P.C.B.

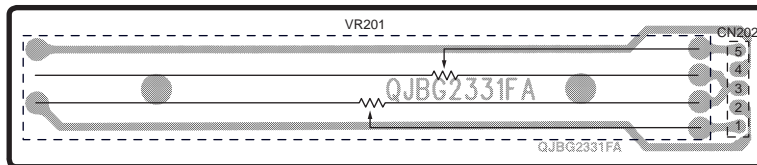

**Y** SUB MASTER OUTPUT P.C.B.

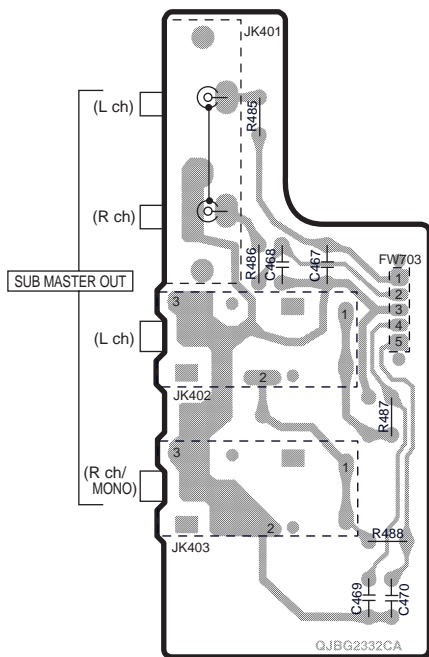

**a** POWER SUPPLY SW P.C.B.

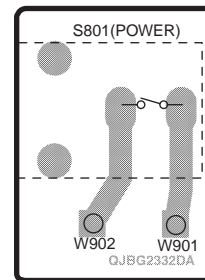

(SXP233211D)



# SCHEMATIC DIAGRAM-1

NOTE: The number which noted at the connectors on the schematic diagram as "SCHEMATIC DIAGRAM-1" or "SCHEMATIC DIAGRAM-2" indicates the schematic diagram serial number located on the left corner in the schematic diagram.

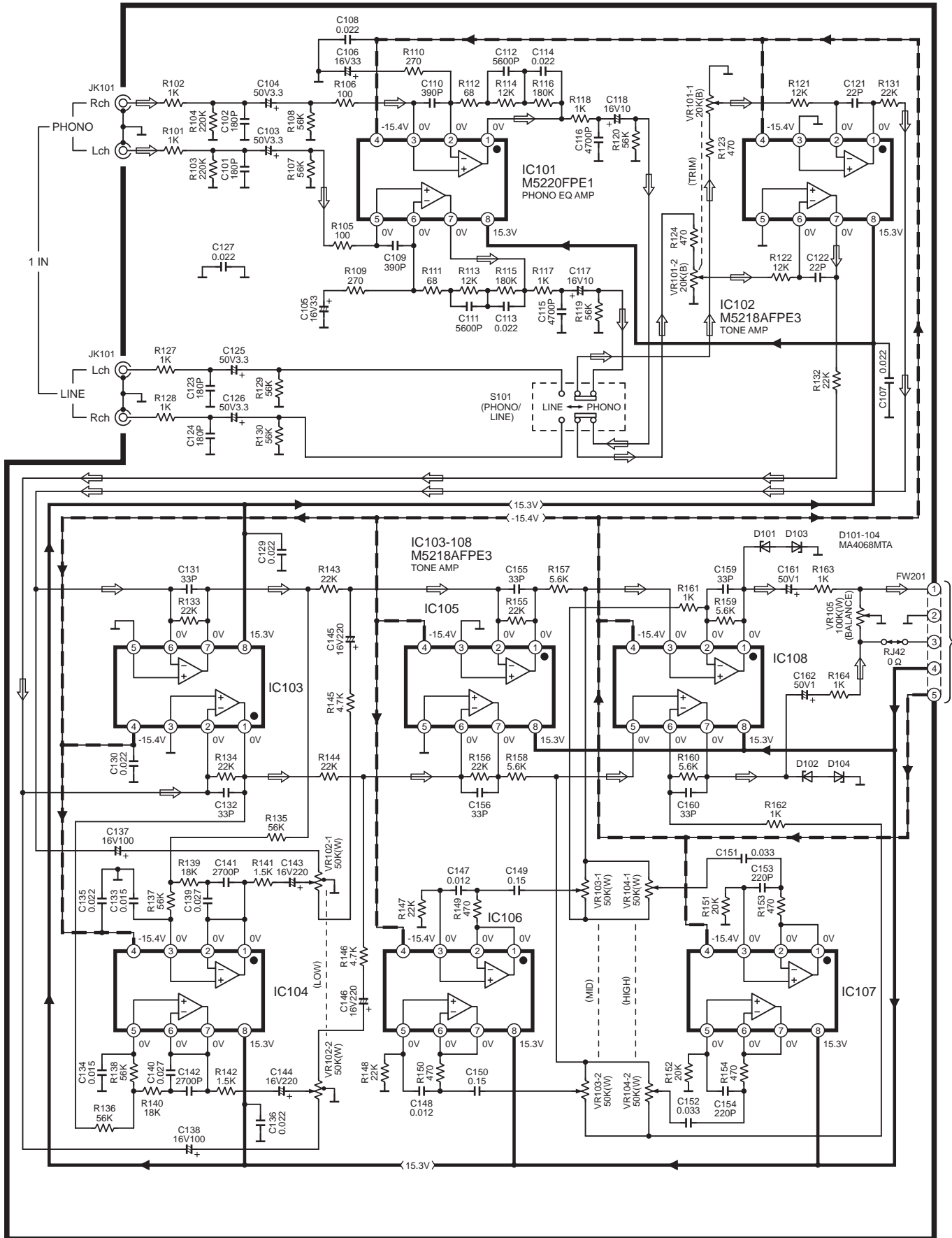

## A INPUT(1) CIRCUIT

→ : POSITIVE VOLTAGE LINE    → - - - : NEGATIVE VOLTAGE LINE    ⇨ : PHONO (1) SIGNAL LINE





# SCHEMATIC DIAGRAM-2

-  : POSITIVE VOLTAGE LINE
-  : NEGATIVE VOLTAGE LINE
-  : PHONO (1) SIGNAL LINE

## K MAIN CIRCUIT

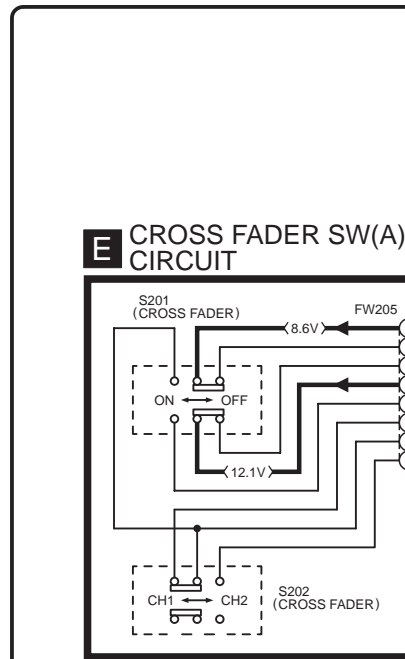

### G FADER(1) CIRCUIT

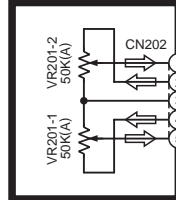

### F CROSS FADER SW(B) CIRCUIT

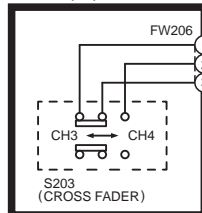

### B INPUT(2) CIRCUIT

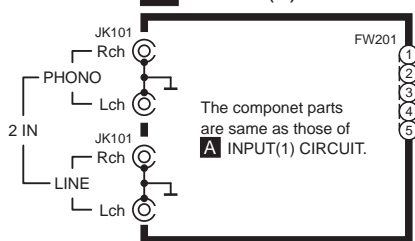

### H FADER(2) CIRCUIT

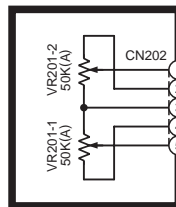

### C INPUT(3) CIRCUIT

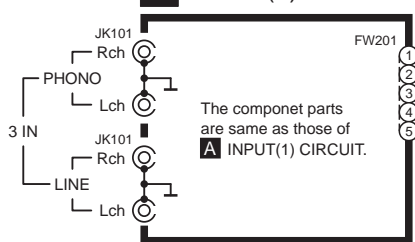

### I FADER(3) CIRCUIT

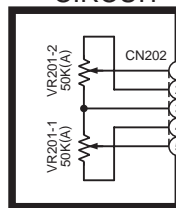

### D INPUT(4) CIRCUIT

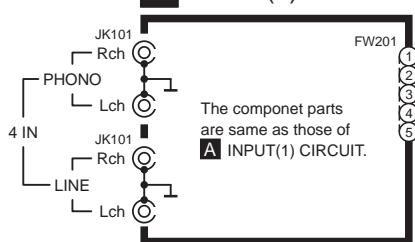

### J FADER(4) CIRCUIT

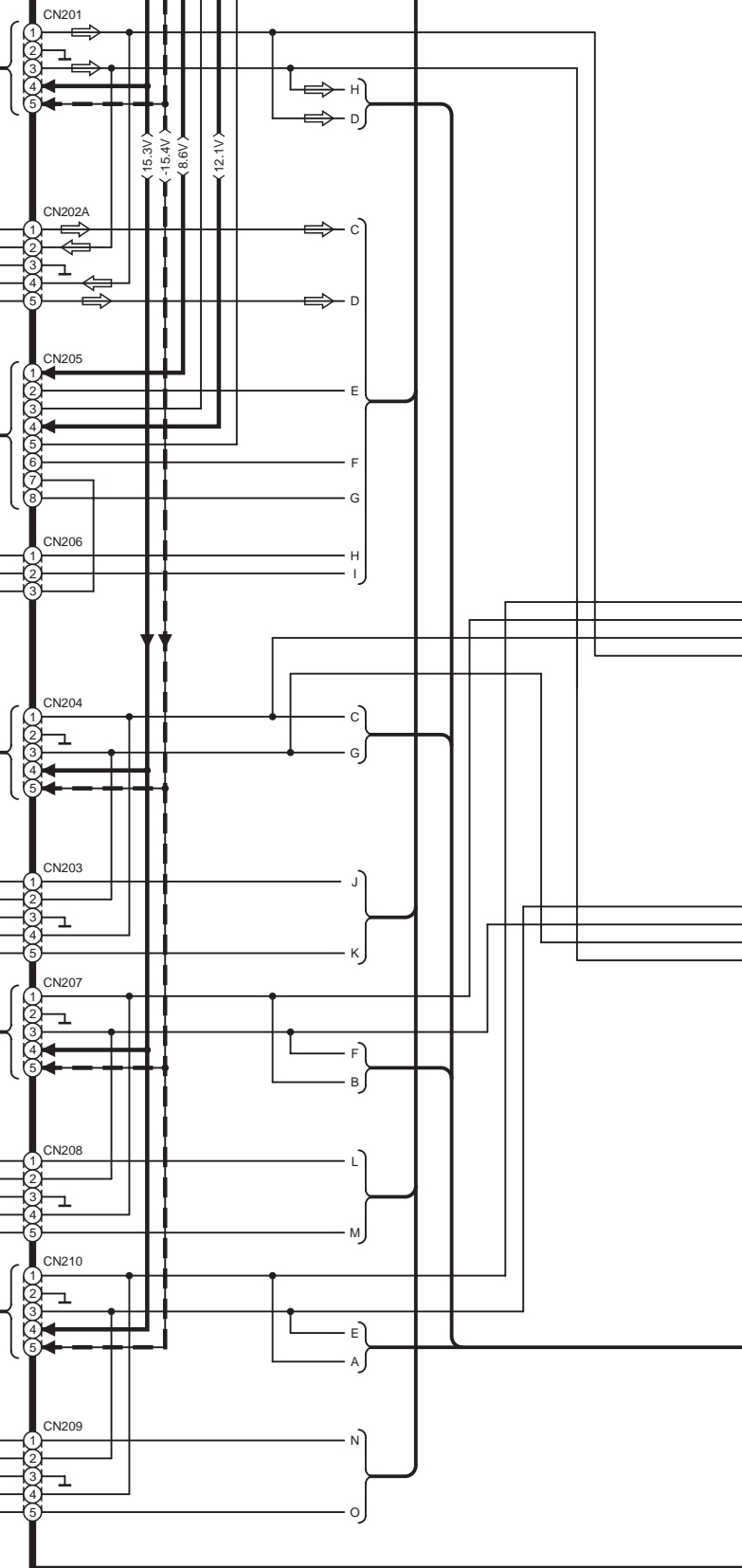
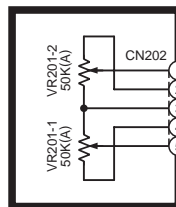

# SCHEMATIC DIAGRAM-3

: POSITIVE VOLTAGE LINE   
  : NEGATIVE VOLTAGE LINE   
  : PHONO (1) SIGNAL LINE   
  : MIC SIGNAL LINE

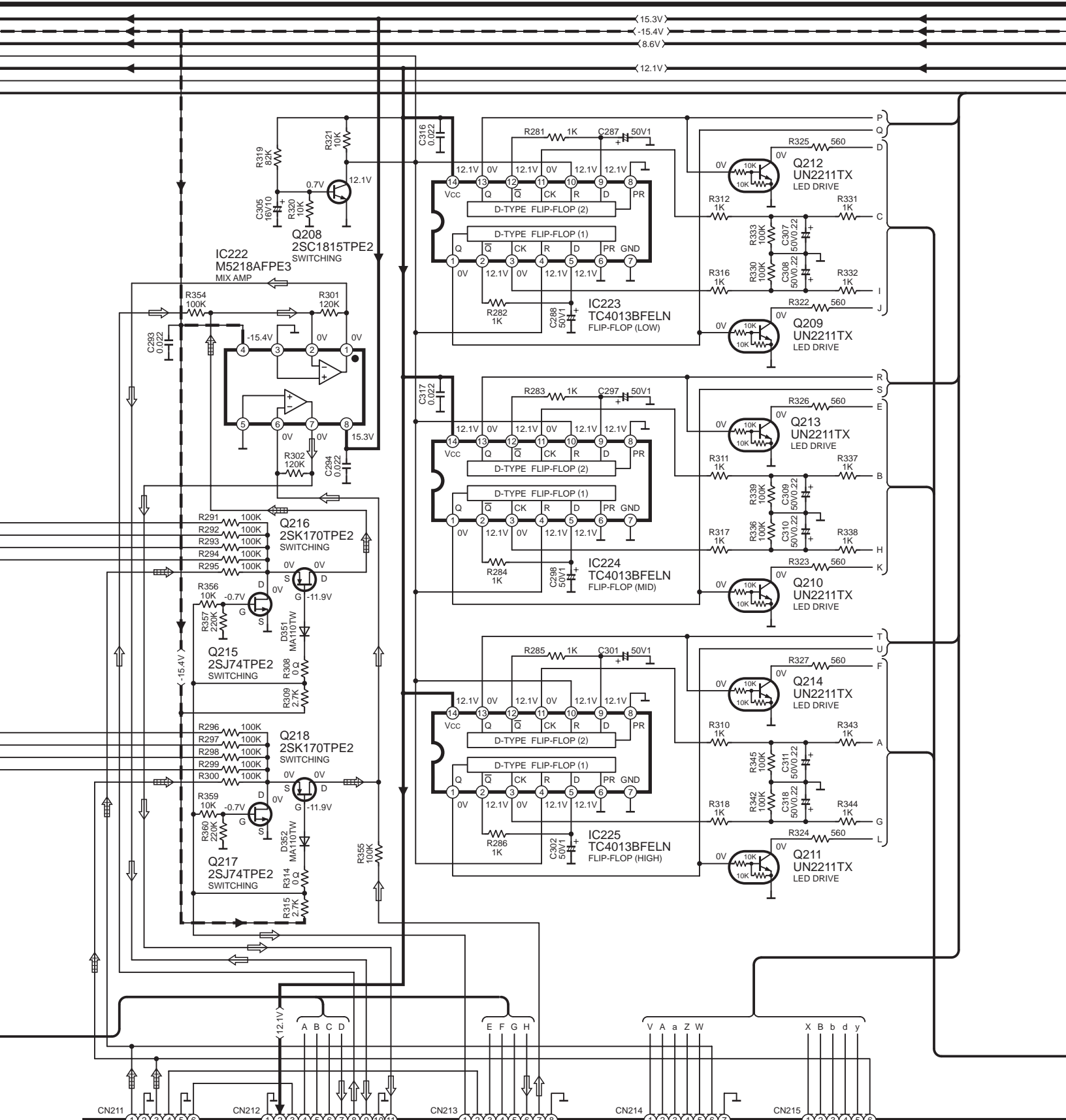

To **Ⓜ** MIC CIRCUIT (FW211) on SCHEMATIC DIAGRAM-12

To **Ⓜ** SIGNAL SELECTOR CIRCUIT (FW212) on SCHEMATIC DIAGRAM-12

To **Ⓜ** SIGNAL SELECTOR CIRCUIT (FW213) on SCHEMATIC DIAGRAM-12

To **Ⓜ** SIGNAL SELECTOR CIRCUIT (FW214) on SCHEMATIC DIAGRAM-12

To **Ⓜ** SIGNAL SELECTOR CIRCUIT (FW215) on SCHEMATIC DIAGRAM-12

SCHEMATIC DIAGRAM-4



MAIN CIRCUIT

→ : POSITIVE VOLTAGE LINE

--- → : NEGATIVE VOLTAGE LINE

⇨ : PHONO (1) SIGNAL LINE

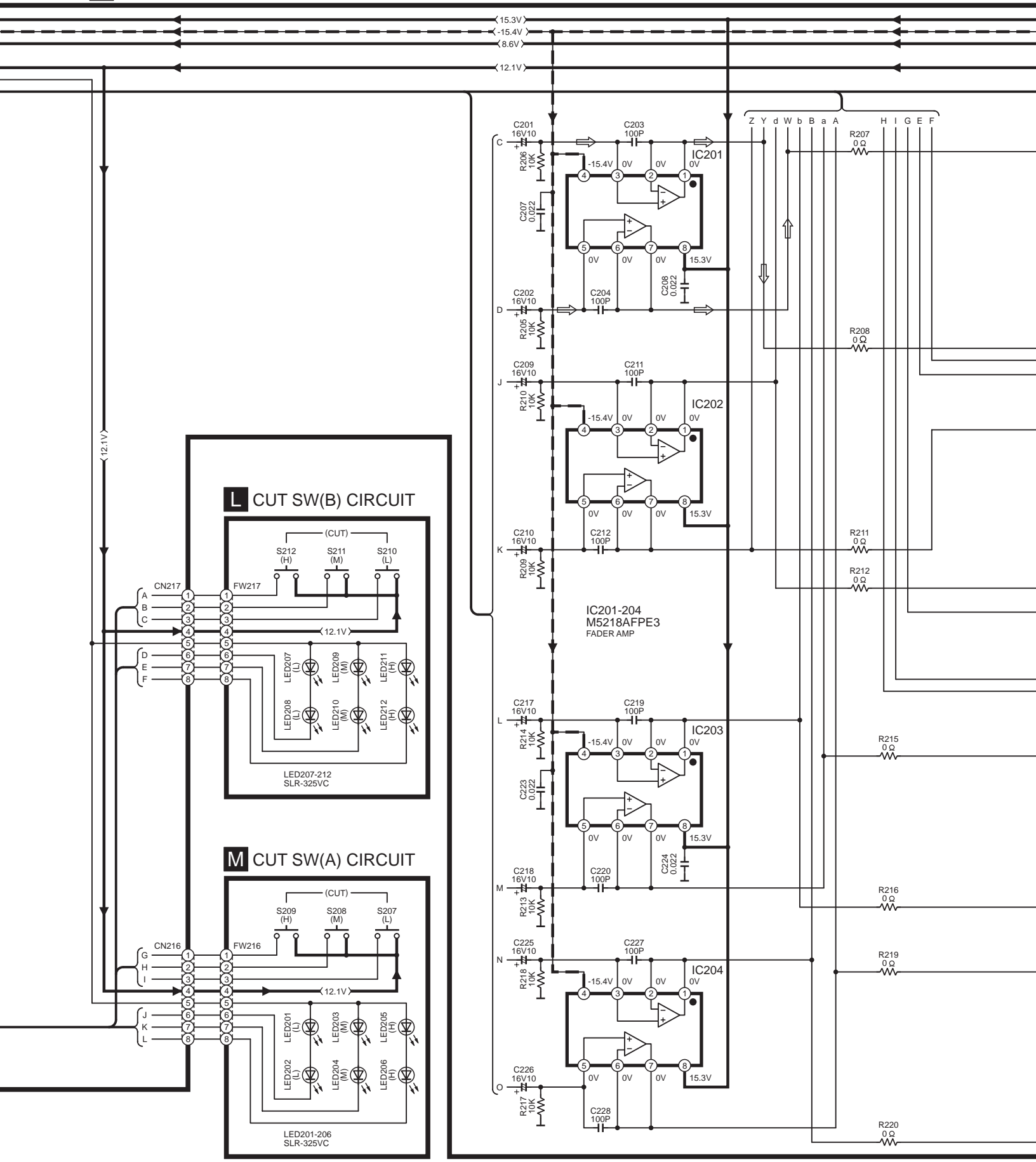

# SCHEMATIC DIAGRAM-5

: POSITIVE VOLTAGE LINE   
  : NEGATIVE VOLTAGE LINE   
  : PHONO (1) SIGNAL LINE

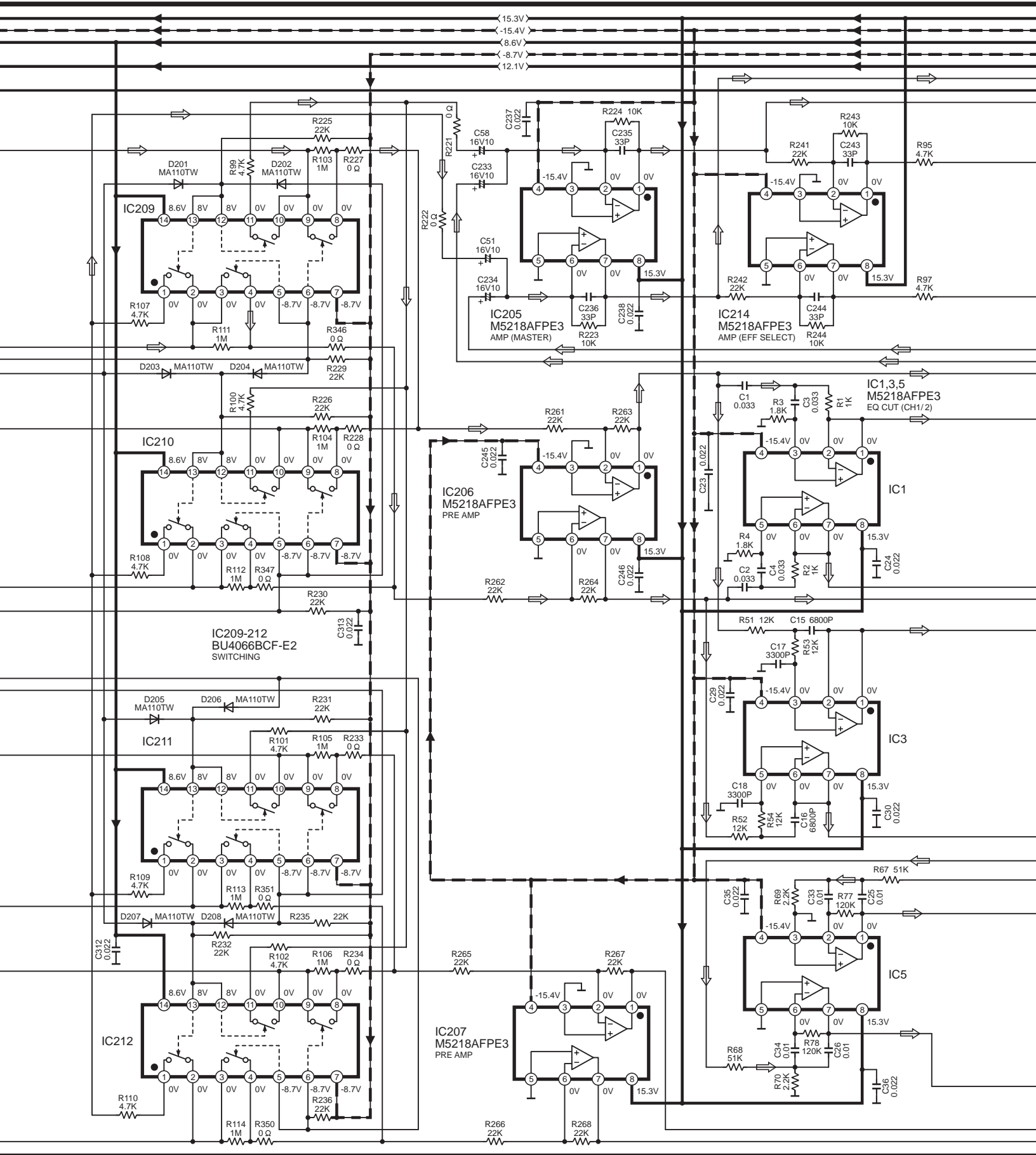

SCHEMATIC DIAGRAM-6

**K** MAIN CIRCUIT

→ : POSITIVE VOLTAGE LINE    -→ : NEGATIVE VOLTAGE LINE    ⇨ : PHONO (1) SIGNAL LINE

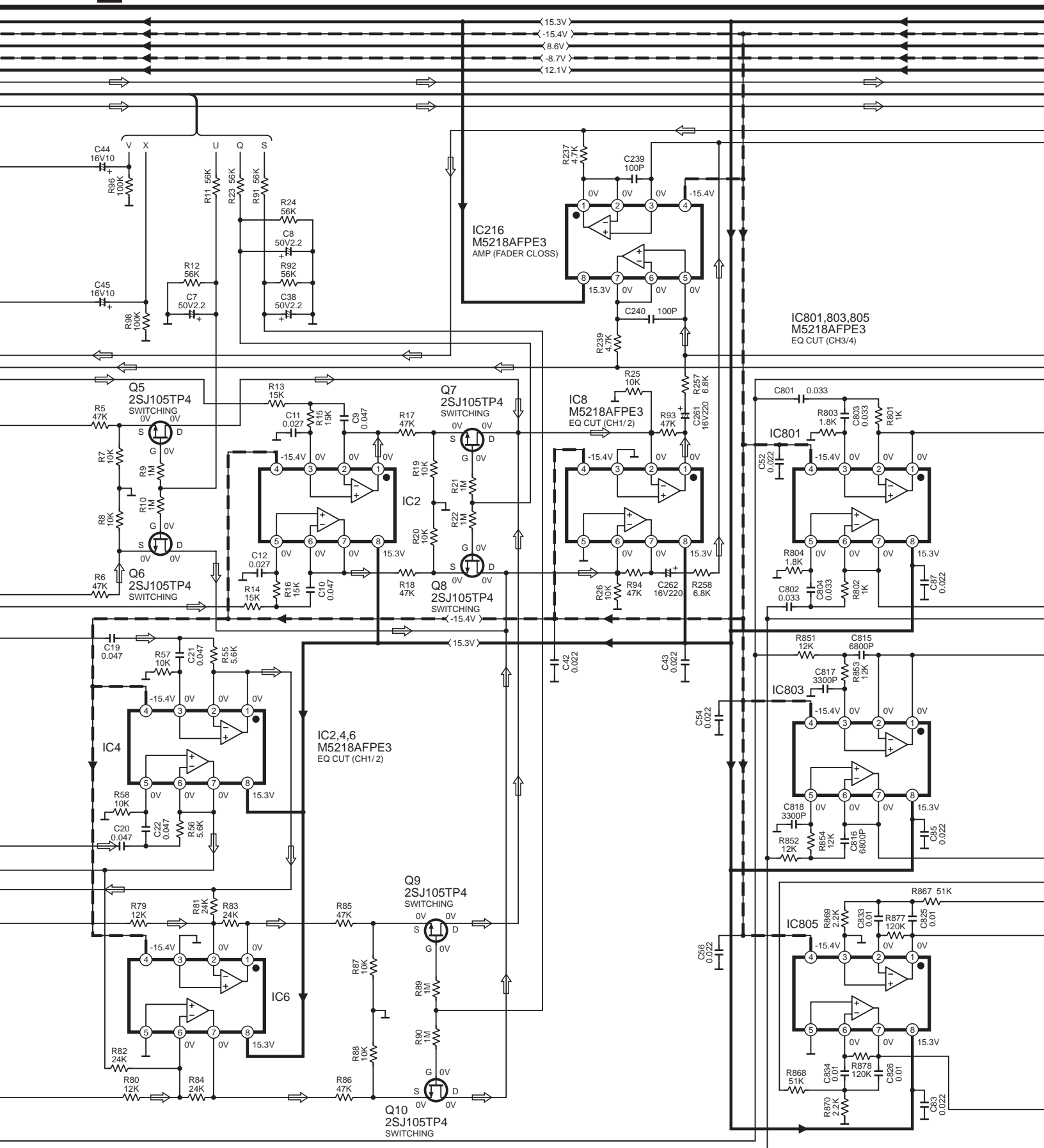

# SCHEMATIC DIAGRAM-7

: POSITIVE VOLTAGE LINE   
  : NEGATIVE VOLTAGE LINE   
  : PHONO (1) SIGNAL LINE

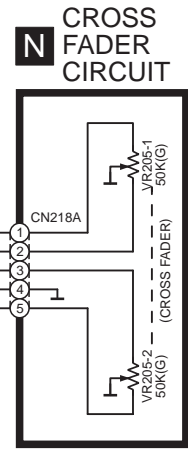
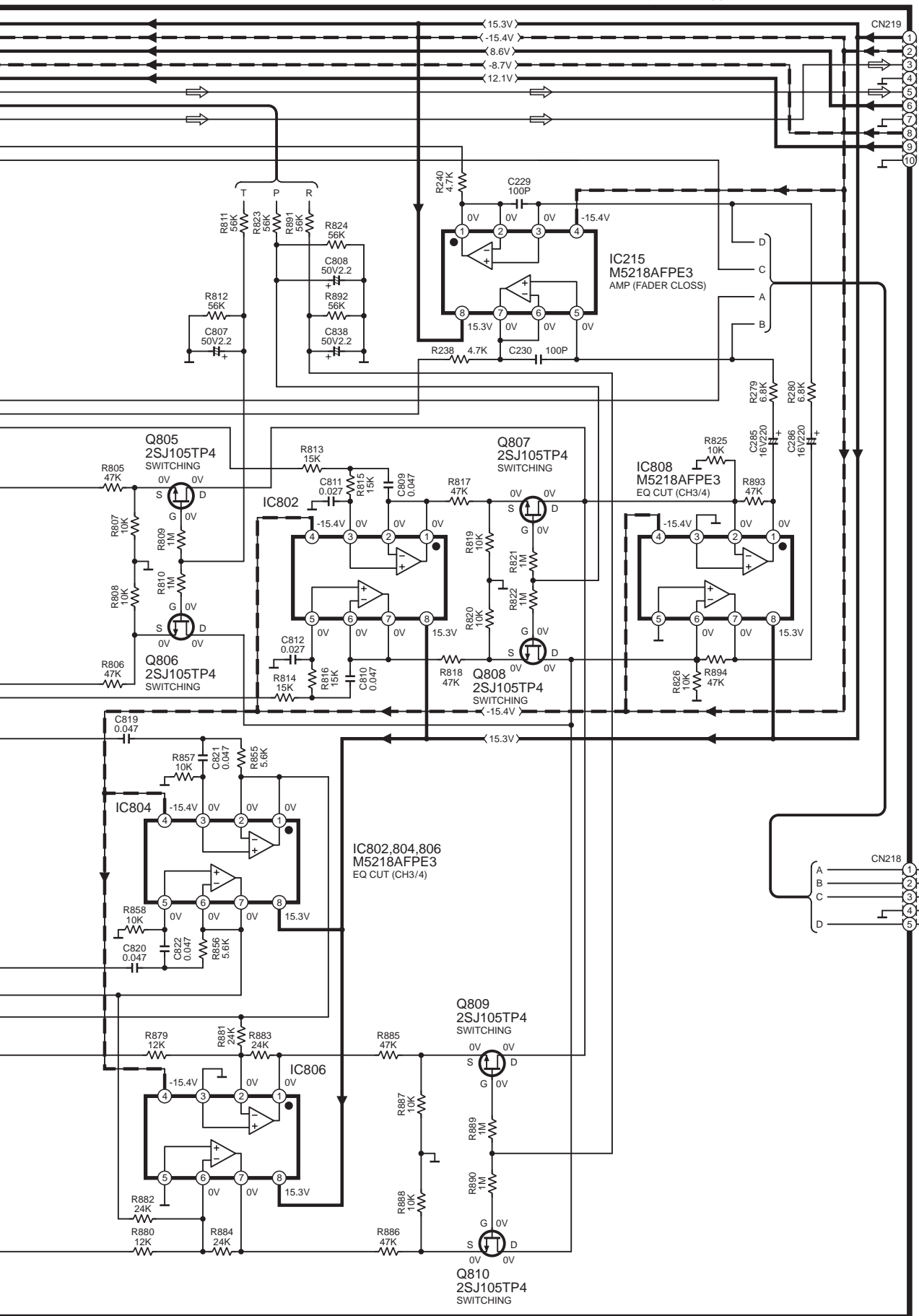

# SCHEMATIC DIAGRAM-8

- : POSITIVE VOLTAGE LINE
- : NEGATIVE VOLTAGE LINE
- ⇨ : PHONO (1) SIGNAL LINE

## P MASTER CUT SW CIRCUIT

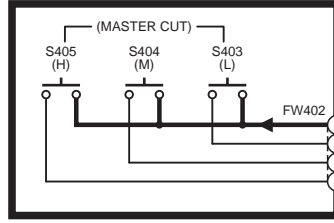

## O LEVEL INDEICATOR CIRCUIT

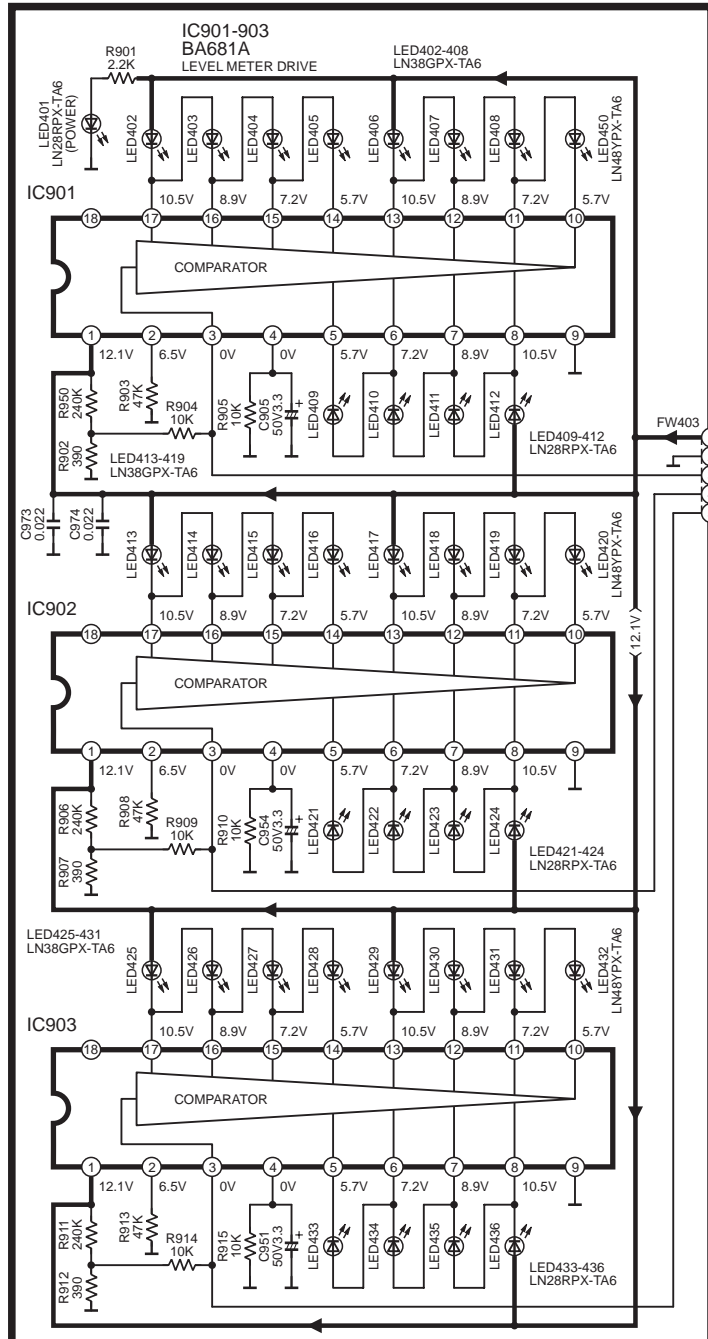

## Q EQ CUT/ MIX CIRCUIT

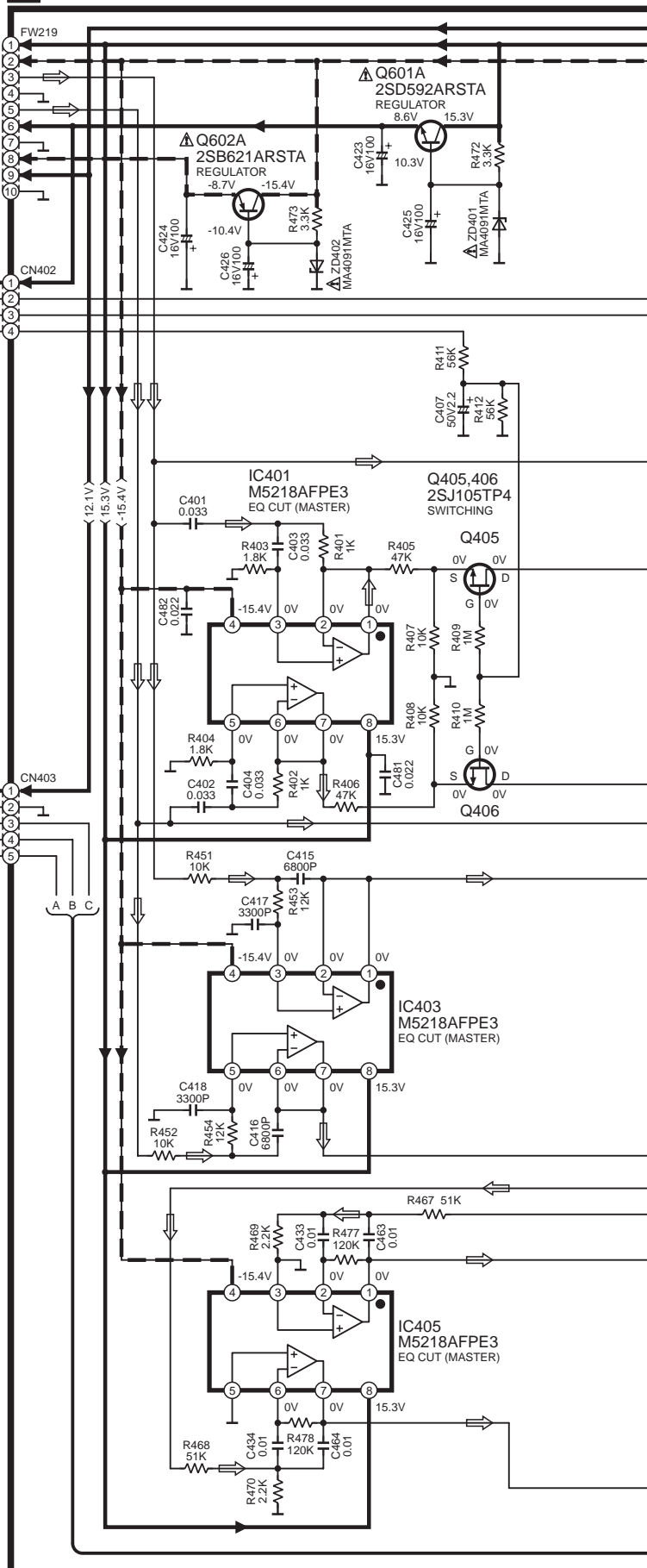





# SCHEMATIC DIAGRAM-10



EQ CUT/ MIX CIRCUIT

→ : POSITIVE VOLTAGE LINE

- - - : NEGATIVE VOLTAGE LINE

⇨ : PHONO (1) SIGNAL LINE

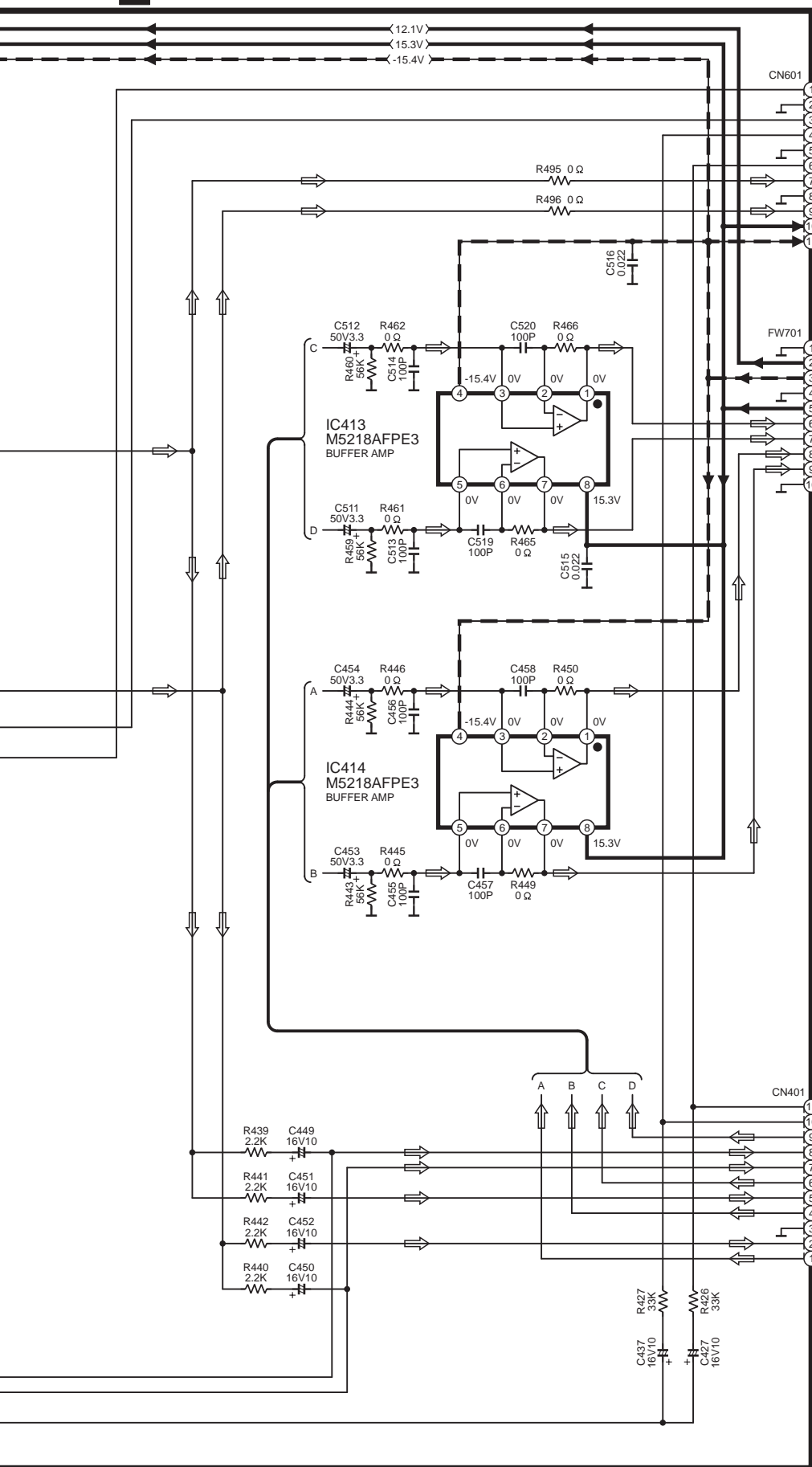

To **W** BALANCE CIRCUIT(FW601) on SCHEMATIC DIAGRAM-13

To **S** IN/OUT TERMINAL CIRCUIT(CN701) on SCHEMATIC DIAGRAM-14

# R MASTER FADER CIRCUIT

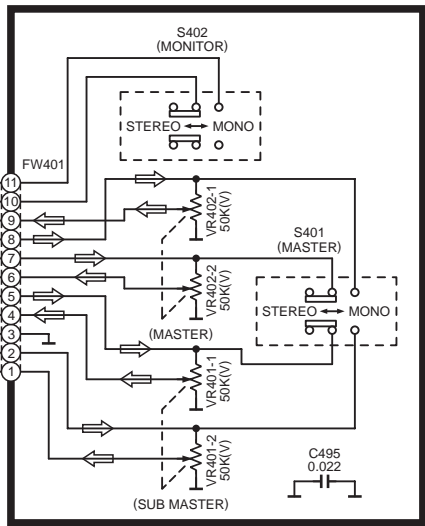

# SCHEMATIC DIAGRAM-11

- ▶— : POSITIVE VOLTAGE LINE
- ◀— : NEGATIVE VOLTAGE LINE
- ⇨ : MIC SIGNAL LINE

## S IN/ OUT TERMINAL CIRCUIT

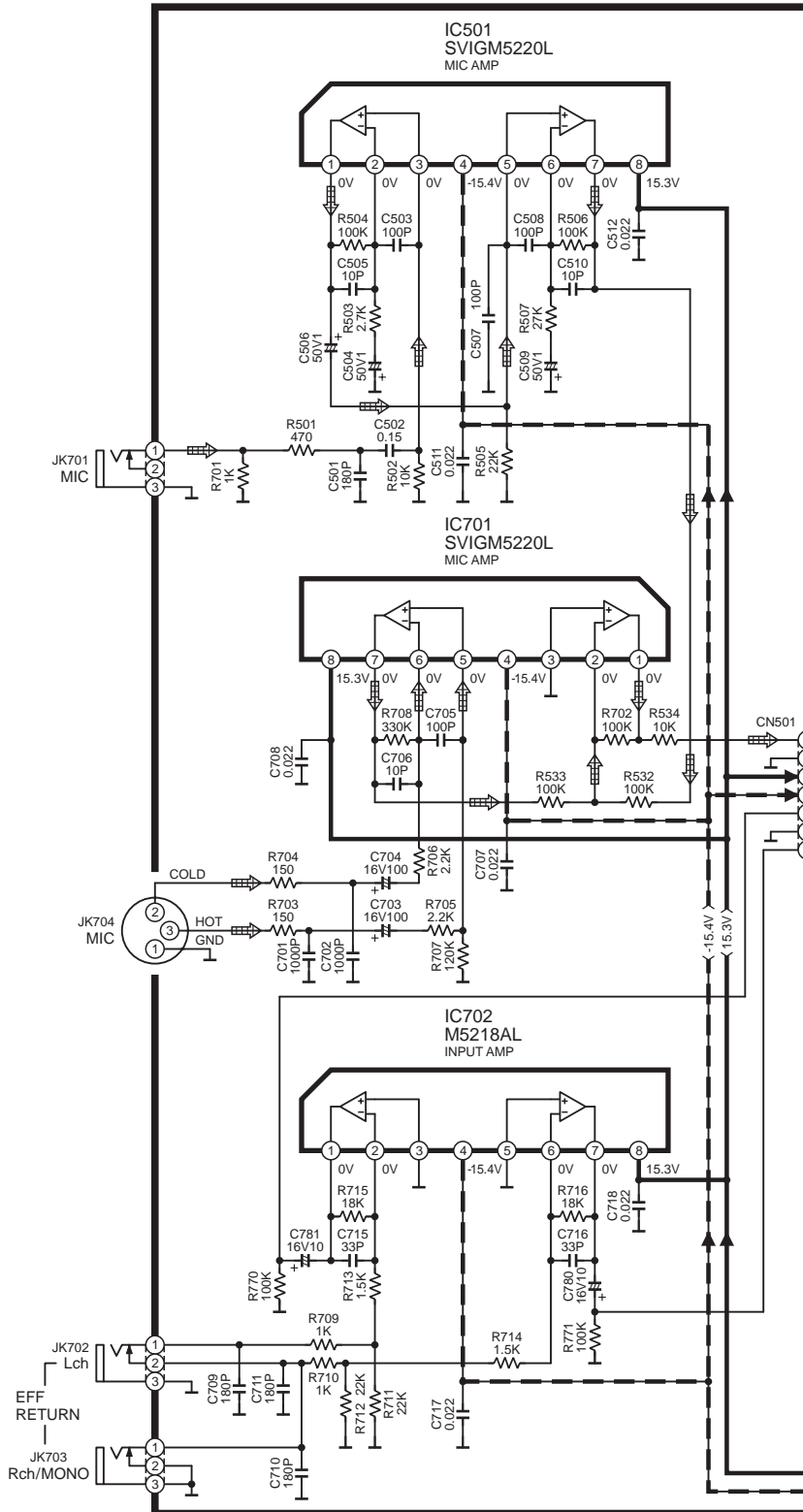

## T MIC CIRCUIT

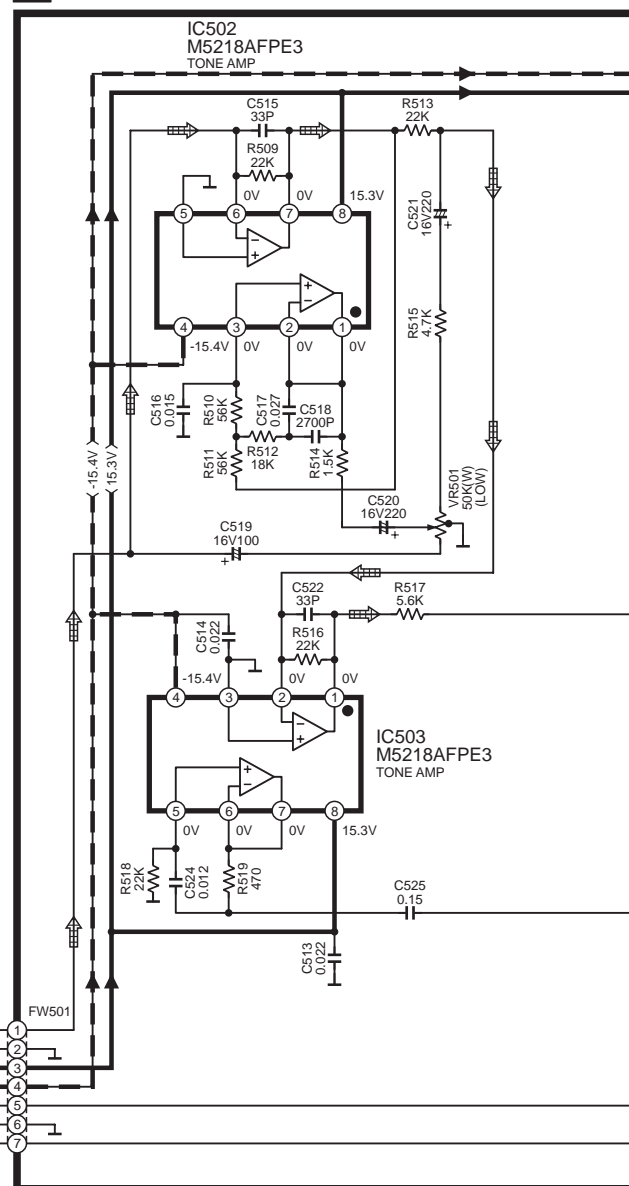

## U CHANNEL VIEW CIRCUIT

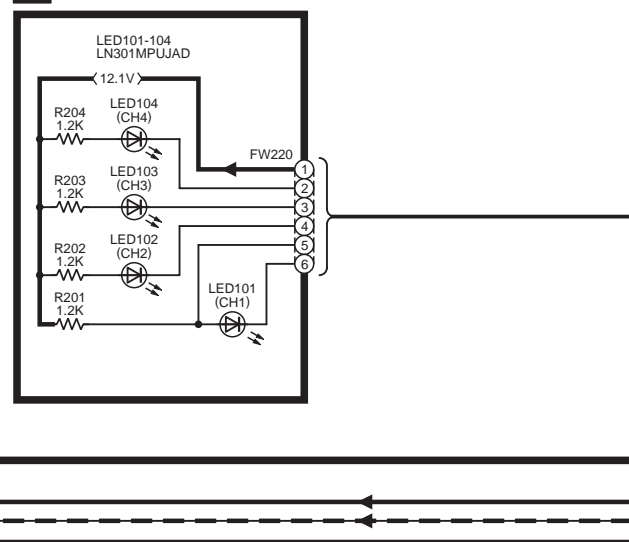

# SCHEMATIC DIAGRAM-12

: POSITIVE VOLTAGE LINE    : PHONO (1) SIGNAL LINE  
 : NEGATIVE VOLTAGE LINE    : MIC SIGNAL LINE

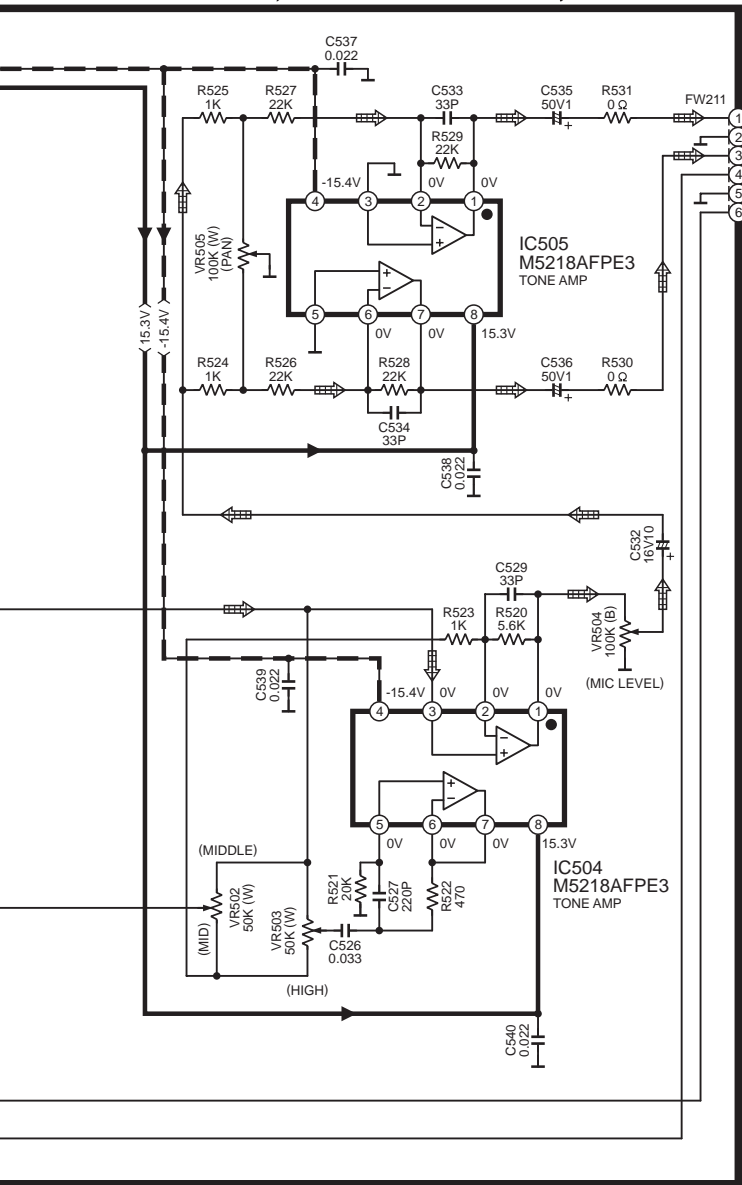

To **K** MAIN CIRCUIT(CN211)  
on SCHEMATIC DIAGRAM-3

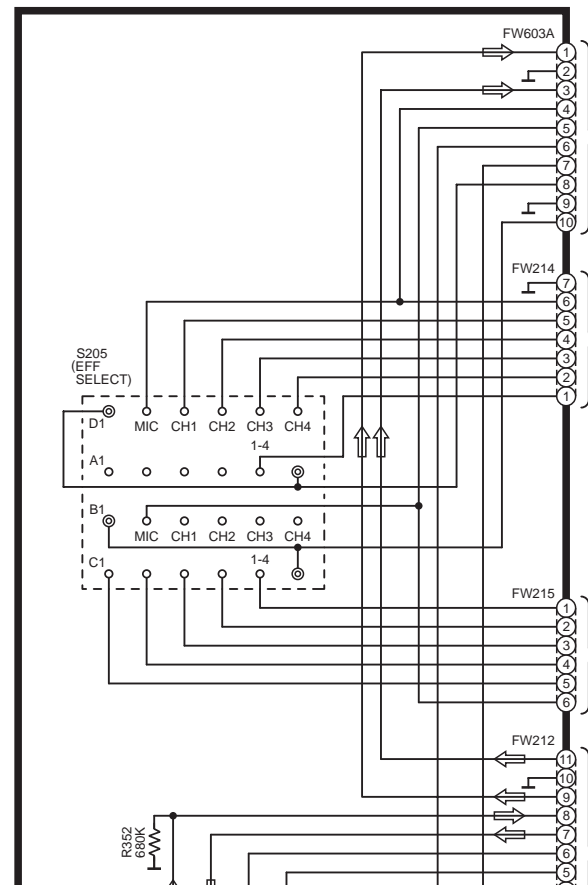

To **K** MAIN CIRCUIT  
(CN214)  
on SCHEMATIC DIAGRAM-3

To **K** MAIN CIRCUIT  
(CN215)  
on SCHEMATIC DIAGRAM-3

To **K** MAIN CIRCUIT  
(CN212)  
on SCHEMATIC DIAGRAM-3

To **K** MAIN CIRCUIT  
(CN213)  
on SCHEMATIC DIAGRAM-3

## V SIGNAL SELECT CIRCUIT

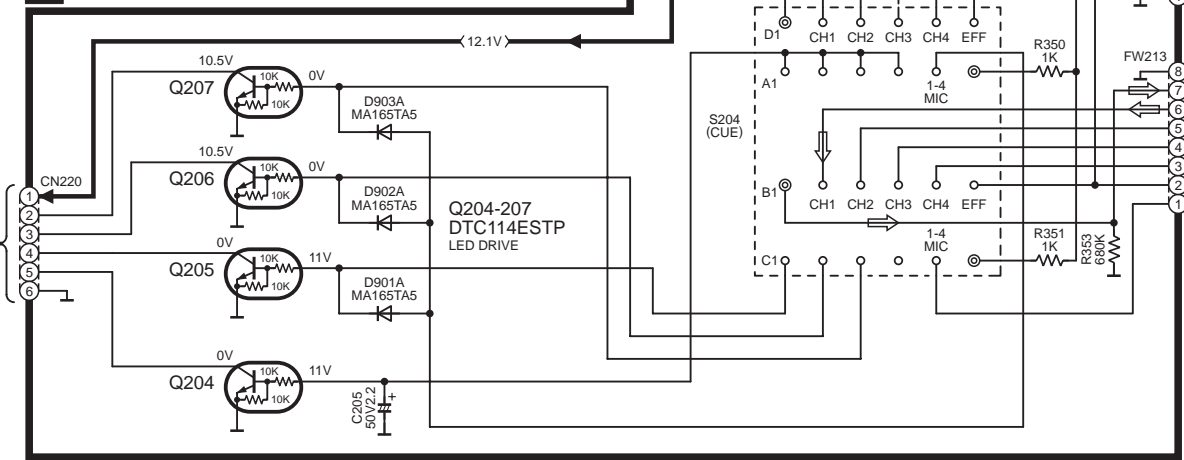

< 15.3V >

< -15.4V >

**SCHEMATIC DIAGRAM-13**

**W BALANCE CIRCUIT**

: POSITIVE VOLTAGE LINE  
 : NEGATIVE VOLTAGE LINE    ⇨ : PHONO (1) SIGNAL LINE

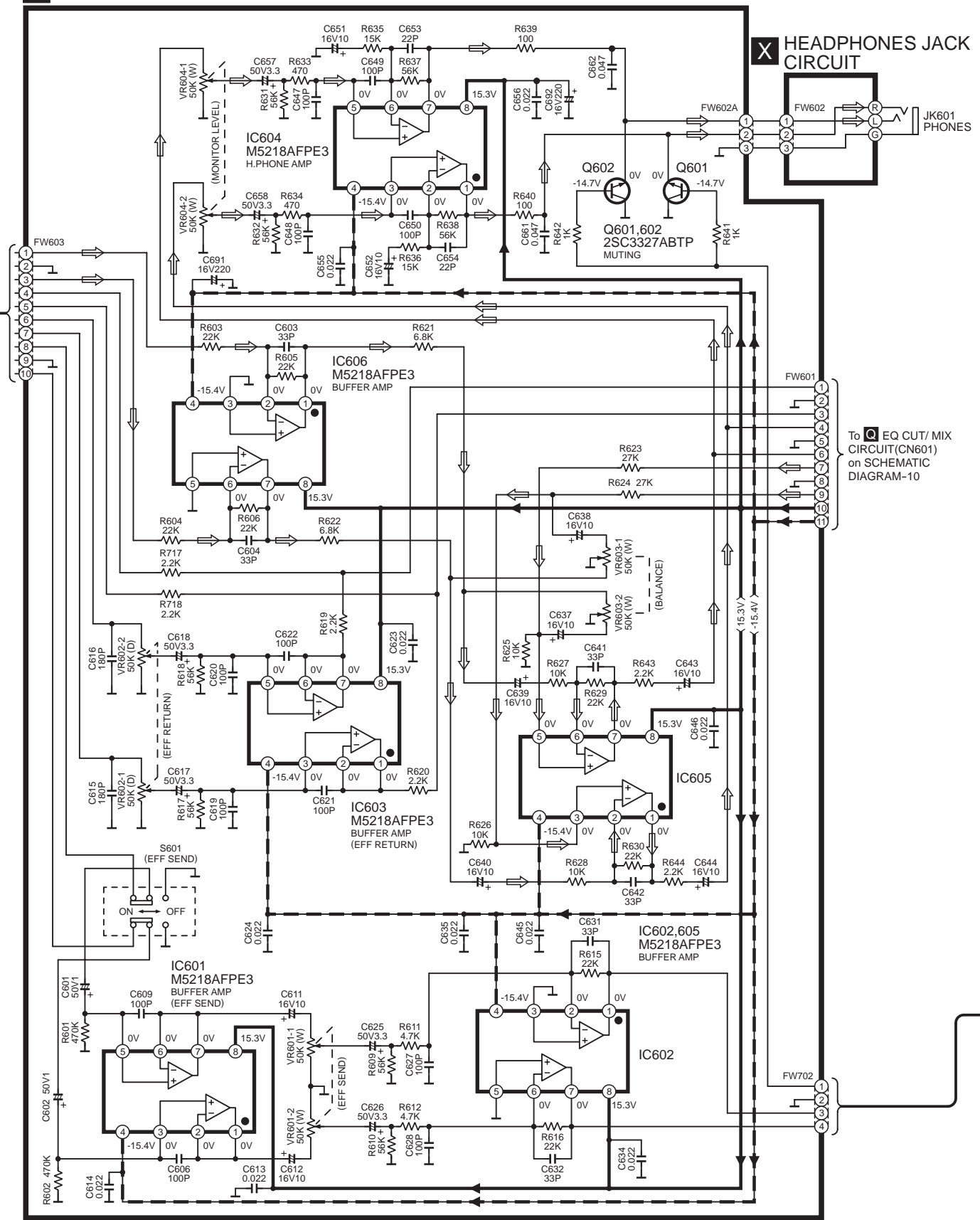

**X HEADPHONES JACK CIRCUIT**

To **Q** EQ CUT/ MIX CIRCUIT (CN601) on SCHEMATIC DIAGRAM-10

15.3V  
-15.4V

**S** IN/ OUT TERMINAL CIRCUIT

— : POSITIVE VOLTAGE LINE  
 - - - : NEGATIVE VOLTAGE LINE  
 ⇨ : PHONO (1) SIGNAL LINE

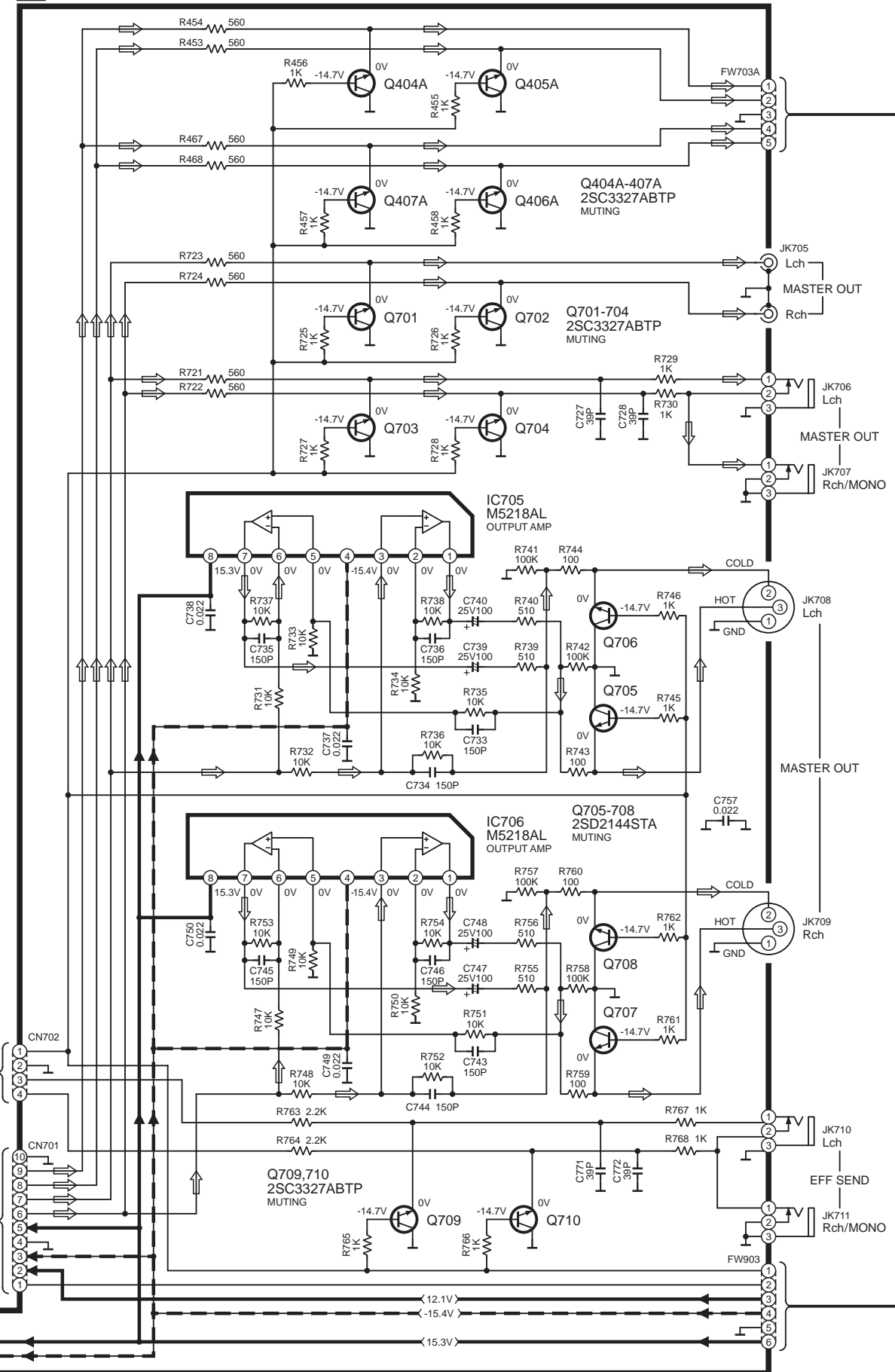

To EQ CUT/MIX  
 CIRCUIT(FW701)  
 on SCHEMATIC  
 DIAGRAM-10

# SCHEMATIC DIAGRAM-15

## Y SUB MASTER OUTPUT CIRCUIT

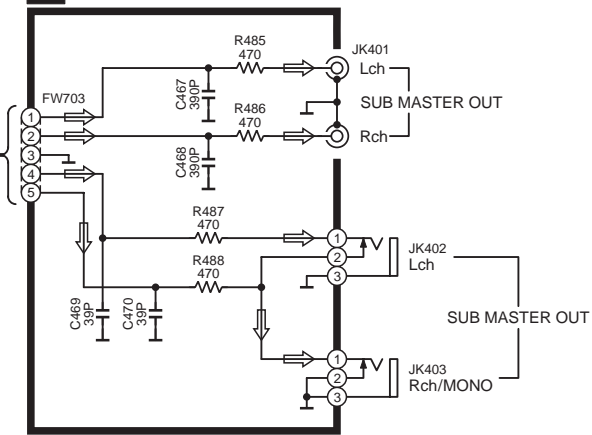

- ▶— : POSITIVE VOLTAGE LINE
- -▶- : NEGATIVE VOLTAGE LINE
- ◁▷ : PHONO (1) SIGNAL LINE

## Z POWER SUPPLY CIRCUIT

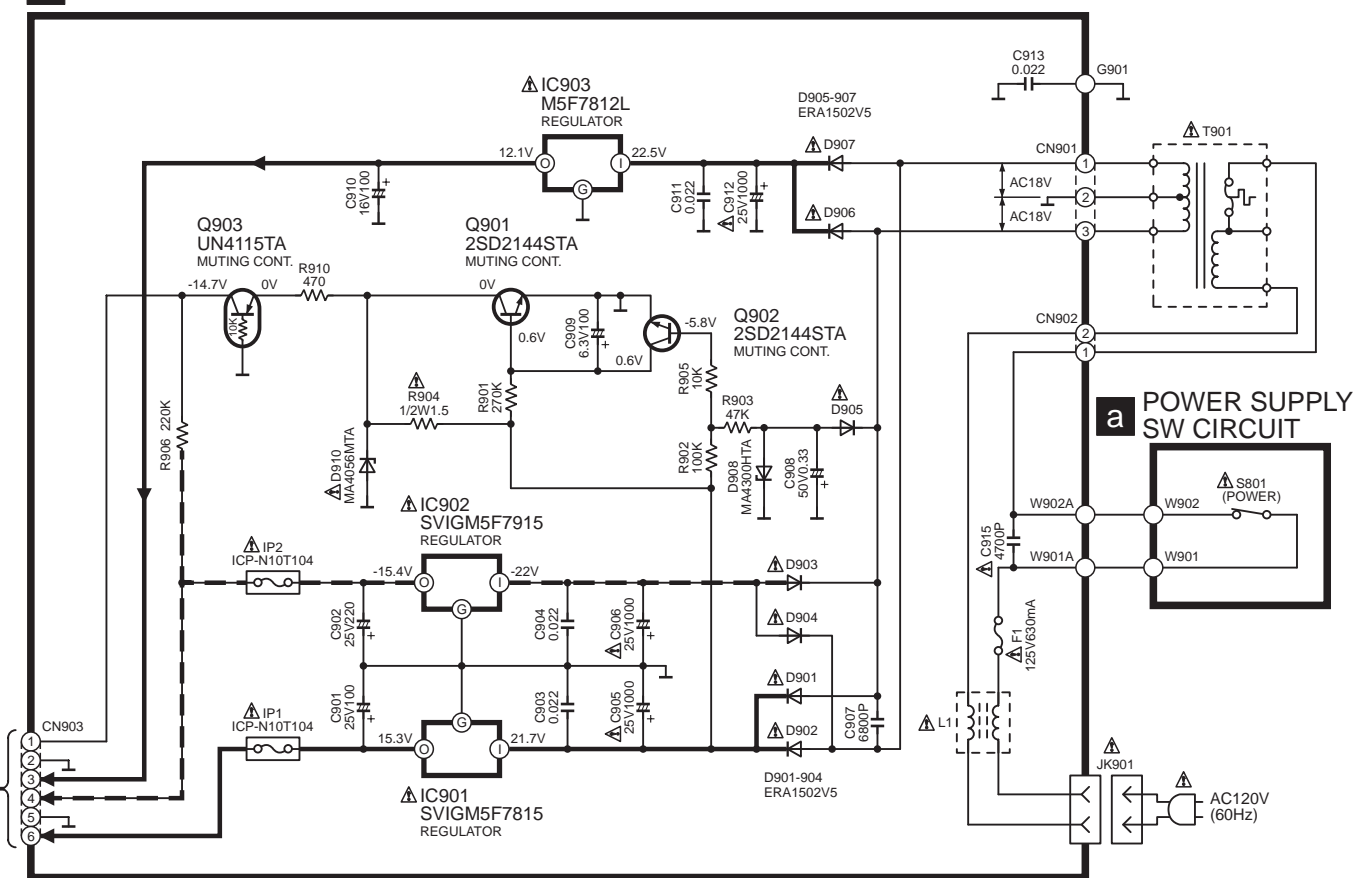

### a POWER SUPPLY SW CIRCUIT

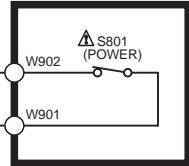

M5220FPE1  
M5218AFPE3

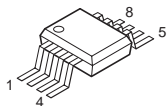

TC4013BFELN

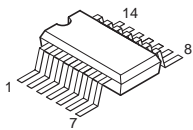

BU4066BCF-E2

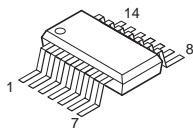

BA681A

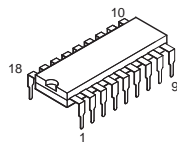

M5218AL

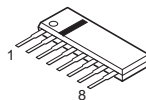

SVIGM5220L

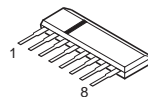

M5F7812L  
SVIGM5F7815

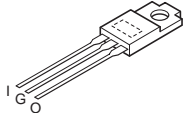

SVIGM5F7915

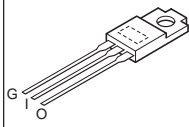

SJ105TP4

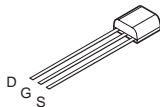

2SJ74TPE2  
2SK170TPE2

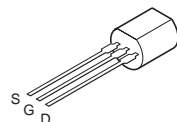

UN2211TX

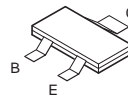

2SC1815TPE2  
2SB621ARSTA  
2SD592ARSTA

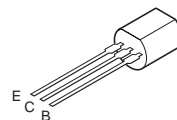

2SC3327ABTP  
DTC114ESTP  
2SD2144STA

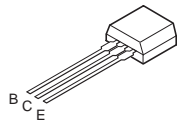

UN4115TA



MA4300HTA

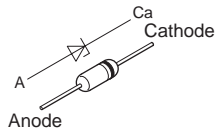

MA110TW

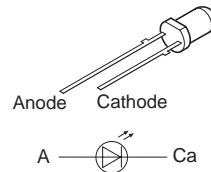
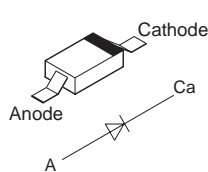

LN28RPX-TA6  
LN38GPX-TA6  
LN48YPX-TA6

SLR-325VC

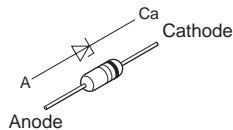
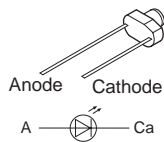

MA4091MTA  
MA4068MTA  
MA4056MTA

LN301MPUJAD

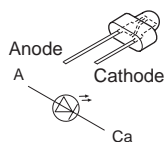

ERA1502V5

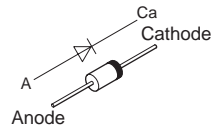

MA165TA5

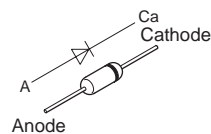

**T** MIC P.C.B.

**E** CROSS FADER SW (A) P.C.B.

**U** CHANNEL VIEW P.C.B.

**G** FADER (1) P.C.B.

**H** FADER (2) P.C.B.

**K** MAIN P.C.B.

**N** CROSS FADER P.C.B.

**I** FADER (3) P.C.B.

**J** FADER (4) P.C.B.

**M** CUT SW (A) P.C.B.

**L** CUT SW (B) P.C.B.

**D** INPUT (4) P.C.B.

**C** INPUT (3) P.C.B.

**F** CROSS FADER SW (B) P.C.B.

**V** SIGNAL SELECT P.C.B.

**B** INPUT (2) P.C.B.

**A** INPUT (1) P.C.B.

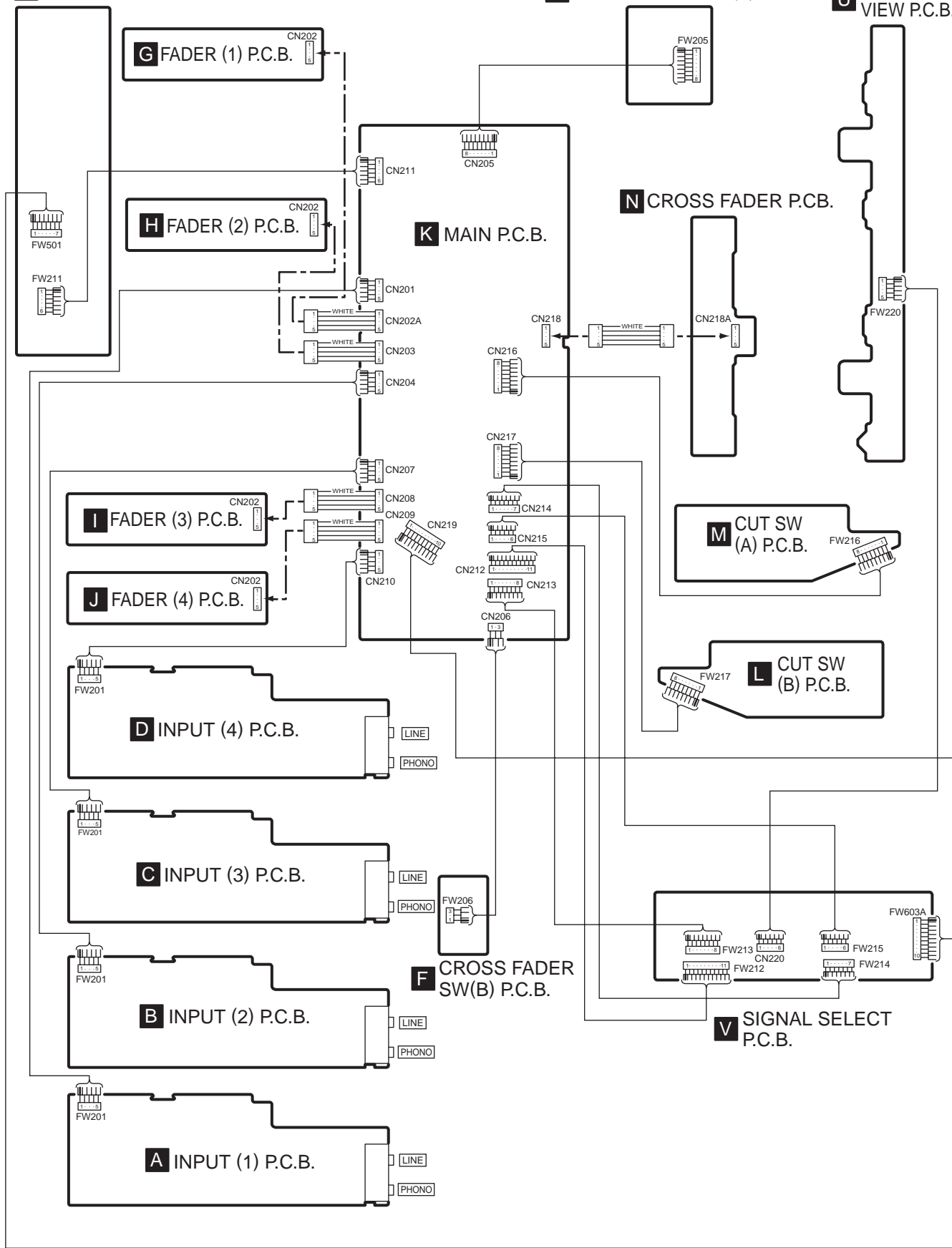



**W** BALANCE P.C.B.

